



Intel[®] Core[™] Duo processor on 65 nm process for Embedded Applications

Thermal Design Guide

February 2006





INFORMATION IN THIS DOCUMENT IS PROVIDED IN CONNECTION WITH INTEL® PRODUCTS. EXCEPT AS PROVIDED IN INTEL'S TERMS AND CONDITIONS OF SALE FOR SUCH PRODUCTS, INTEL ASSUMES NO LIABILITY WHATSOEVER, AND INTEL DISCLAIMS ANY EXPRESS OR IMPLIED WARRANTY RELATING TO SALE AND/OR USE OF INTEL PRODUCTS, INCLUDING LIABILITY OR WARRANTIES RELATING TO FITNESS FOR A PARTICULAR PURPOSE, MERCHANTABILITY, OR INFRINGEMENT OF ANY PATENT, COPYRIGHT, OR OTHER INTELLECTUAL PROPERTY RIGHT.

Intel Corporation may have patents or pending patent applications, trademarks, copyrights, or other intellectual property rights that relate to the presented subject matter. The furnishing of documents and other materials and information does not provide any license, express or implied, by estoppel or otherwise, to any such patents, trademarks, copyrights, or other intellectual property rights.

Intel products are not intended for use in medical, life saving, life sustaining, critical control or safety systems, or in nuclear facility applications.

Intel may make changes to specifications and product descriptions at any time, without notice.

Designers must not rely on the absence or characteristics of any features or instructions marked "reserved" or "undefined." Intel reserves these for future definition and shall have no responsibility whatsoever for conflicts or incompatibilities arising from future changes to them.

The Intel® Core™ Duo processor on 65 nm process for Embedded Applications may contain design defects or errors known as errata which may cause the product to deviate from published specifications. Current characterized errata are available on request.

This Thermal Design Guide as well as the software described in it is furnished under license and may only be used or copied in accordance with the terms of the license. The information in this manual is furnished for informational use only, is subject to change without notice, and should not be construed as a commitment by Intel Corporation. Intel Corporation assumes no responsibility or liability for any errors or inaccuracies that may appear in this document or any software that may be provided in association with this document.

Except as permitted by such license, no part of this document may be reproduced, stored in a retrieval system, or transmitted in any form or by any means without the express written consent of Intel Corporation.

Contact your local Intel sales office or your distributor to obtain the latest specifications and before placing your product order.

Copies of documents which have an ordering number and are referenced in this document, or other Intel literature may be obtained by calling 1-800-548-4725 or by visiting Intel's website at <http://www.intel.com>.

AnyPoint, AppChoice, BoardWatch, BunnyPeople, CablePort, Celeron, Chips, CT Media, Dialogic, DM3, EtherExpress, ETOX, FlashFile, i386, i486, i960, iCOMP, InstantIP, Intel, Intel Centrino, Intel logo, Intel386, Intel486, Intel740, IntelDX2, IntelDX4, IntelSX2, Intel Create & Share, Intel GigaBlade, Intel InBusiness, Intel Inside, Intel Inside logo, Intel NetBurst, Intel NetMerge, Intel NetStructure, Intel Play, Intel Play logo, Intel SingleDriver, Intel SpeedStep, Intel StrataFlash, Intel TeamStation, Intel Xeon, Intel XScale, IPLink, Itanium, MCS, MMX, MMX logo, Optimizer logo, OverDrive, Paragon, PC Dads, PC Parents, PDCharm, Pentium, Pentium II Xeon, Pentium III Xeon, Performance at Your Command, RemoteExpress, SmartDie, Solutions960, Sound Mark, StorageExpress, The Computer Inside., The Journey Inside, TokenExpress, VoiceBrick, VTune, and Xircom are trademarks or registered trademarks of Intel Corporation or its subsidiaries in the United States and other countries.

*Other names and brands may be claimed as the property of others.

Copyright © 2006, Intel Corporation. All Rights Reserved.

Contents

1	Introduction.....	7
1.1	Design Flow.....	7
1.2	Definition of Terms.....	8
1.3	Reference Documents.....	9
1.4	Thermal Design Tool Availability.....	9
2	Package Information.....	10
3	Thermal Specifications.....	15
3.1	Thermal Design Power.....	15
3.2	Maximum Allowed Component Temperature.....	15
4	Mechanical Specifications.....	16
4.1	Package Mechanical Requirements.....	16
4.2	Package Keep Out Zones Requirements.....	16
4.3	Board Level Keep Out Zone Requirements.....	16
5	Thermal Solution Requirements.....	20
5.1	Characterizing the Thermal Solution Requirement.....	20
5.1.1	Calculating the Required Thermal Performance for the Intel® Core™ Duo processor LV.....	21
6	Reference Thermal Solution.....	23
6.1	CompactPCI* Reference Heatsink.....	23
6.1.1	Mechanical Design.....	23
6.1.2	Keep Out Zone Requirements.....	24
6.1.3	Thermal Performance.....	24
6.2	AdvancedTCA* Reference Heatsink.....	25
6.2.1	Mechanical Design.....	25
6.2.2	Keep Out Zone Requirements.....	26
6.2.3	Thermal Performance.....	26
6.3	1U+ Reference Heatsink.....	27
6.3.1	Mechanical Design.....	27
6.3.2	Keep Out Zone Requirements.....	28
6.3.3	Thermal Performance.....	28
6.4	Heatsink Fastener Assembly.....	29
6.5	Thermal Interface Material (TIM).....	29
6.6	Heatsink Orientation.....	30
7	Thermal Metrology.....	31
7.1	Die Temperature Measurements.....	31
7.2	Power Simulation Software.....	31
7.3	Additional Thermal Features.....	31
7.4	Local Ambient Temperature Measurement Guidelines.....	32
7.4.1	Active Heatsink Measurements.....	32
7.4.2	Passive Heatsink Measurements.....	32
8	Reliability Guidelines.....	35

A	Thermal Solution Component Suppliers.....	36
B	Mechanical Drawings	37

Figures

1	Thermal Design Process	8
2	Micro-FCPGA Package (Sheet 1 of 2)	11
3	Micro-FCPGA Package (Sheet 2 of 2)	12
4	Micro-FCBGA Package (Sheet 1 of 2)	13
5	Micro-FCBGA Package (Sheet 2 of 2)	14
6	Primary Side Keep Out Zone Requirements— Micro-FCPGA	17
7	Primary Side Keep Out Zone Requirements— Micro-FCBGA	18
8	Secondary Side Keep Out Zone Requirements	19
9	Processor Thermal Characterization Parameter Relationships.....	21
10	Compact PCI* Reference Heatsink Assembly.....	24
11	CompactPCI* Heatsink Thermal Performance vs. Volumetric Airflow Rate	25
12	AdvancedTCA* Reference Heatsink Assembly	26
13	AdvancedTCA* Heatsink Thermal Performance vs. Volumetric Airflow Rate	27
14	1U Reference Heatsink Assembly	28
15	1U Heatsink Thermal Performance vs. Volumetric Airflow Rate	29
16	Heatsink Orientation Relative to Airflow Direction	30
17	Measuring TLA with an Active Heatsink	33
18	Measuring TLA with a Passive Heatsink	34
19	AdvancedTCA* Reference Heatsink PCB Keep Out Zone Requirements (Sheet 1 of 2)	38
20	AdvancedTCA* Reference Heatsink PCB Keep Out Zone Requirements (Sheet 2 of 2).....	39
21	AdvancedTCA* Reference Heatsink Assembly	40
22	AdvancedTCA* Reference Heatsink	41
23	CompactPCI* Reference Heatsink PCB Keep Out Zone Requirements (Sheet 1 of 2)	42
24	CompactPCI* Reference Heatsink PCB Keep Out Zone Requirements (Sheet 2 of 2)	43
25	CompactPCI* Reference Heatsink Assembly.....	44
26	CompactPCI* Reference Heatsink	45
27	1U Reference Heatsink PCB Keep Out Requirements (Sheet 1 of 2).....	46
28	1U Reference Heatsink PCB Keep Out Requirements (Sheet 2 of 2).....	47
29	1U Reference Heatsink Assembly.....	48
30	1U Reference Heatsink	49

Tables

1	Definition of Terms	8
2	Thermal Specifications for the Intel® Core™ Duo processor.....	15
3	Required Heatsink Thermal Performance (YJA)	22
4	Reliability Requirements.....	35
5	Mechanical Drawings	37



Revision History

Date	Revision	Description
February 2006	001	Initial public release



Introduction

1

The power dissipation of electronic components has risen along with the increase in complexity of computer systems. To ensure quality, reliability, and performance goals are met over the product's life cycle, the heat generated by the device must be properly dissipated. Typical methods to improve heat dissipation include selective use of airflow ducting, and/or the use of heatsinks.

The goals of this document are to:

- Specify the thermal and mechanical specification for the device.
- Describe a reference thermal solution that meets the specifications.

A properly designed thermal solution will adequately cool the device at or below the thermal specification. This is accomplished by providing a suitable local-ambient temperature, ensuring adequate local airflow, and minimizing the die to local-ambient thermal resistance. Operation outside the functional limits can degrade system performance and may cause permanent changes in the operating characteristics of the component.

This document describes thermal design guidelines for the Intel® Core™ Duo processor on 65 nm process for Embedded Applications in the micro Flip Chip Pin Grid Array (micro-FCPGA) package and the micro Flip Chip Ball Grid Array (micro-FCBGA) package. Detailed mechanical and thermal specifications for these processors can be found in the Intel® Core™ Duo processor *and Intel® Core™ Solo processor on 65 nm process Datasheet*.

The information provided in this document is for reference only and additional validation must be performed prior to implementing the designs into final production. The intent of this document is to assist each original equipment manufacturer (OEM) with the development of thermal solutions for their individual designs. The final heatsink solution, including the heatsink, attachment method, and thermal interface material (TIM) must comply with the mechanical design, environmental, and reliability requirements delineated in the processor datasheet. It is the responsibility of each OEM to validate the thermal solution design with their specific applications.

This document addresses thermal and mechanical design specifications for Intel Core Duo processors only. For thermal design information on other Intel components, refer to the respective component datasheet.

1.1 Design Flow

Several tools are available from Intel to assist in the development of a reliable, cost-effective thermal solution. [Figure 1](#) illustrates a typical thermal solution design process with available tools noted. The tools are available through your local Intel field sales representative.

Figure 1. Thermal Design Process

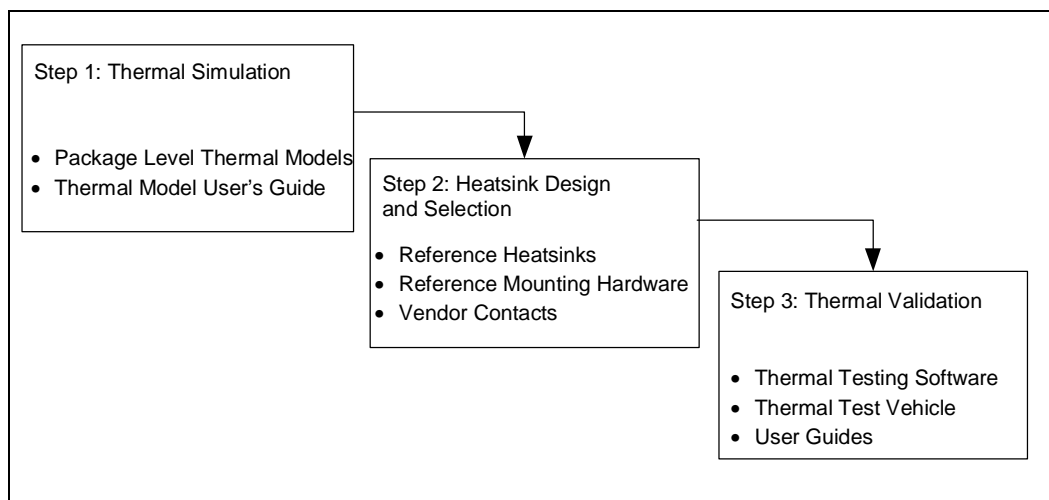

1.2 Definition of Terms

Table 1. Definition of Terms (Sheet 1 of 2)

Term	Definition
FCPGA	Flip Chip Pin Grid Array. A pin grid array packaging technology where the die is exposed on the package substrate.
FCBGA	Flip Chip Ball Grid Array. A ball grid array packaging technology where the die is exposed on the package substrate.
$T_{\text{JUNCTION-MAX}}$	Maximum allowed component (junction) temperature. Also referred to as $T_{\text{J-MAX}}$
TDP	Thermal Design Power. Thermal solutions should be designed to dissipate this target power level.
T_{LA}	Local ambient temperature. This is the temperature measured inside the chassis, approximately 1" upstream of a component heatsink. Also referred to as T_{A} .
Ψ_{JA}	Junction-to-ambient thermal characterization parameter. A measure of heatsink thermal performance using the total package power. Defined as $(T_{\text{JUNCTION}} - T_{\text{LA}}) / \text{Total Package Power}$
Ψ_{TIM}	Thermal interface material thermal characterization parameter. A measure of thermal interface material performance using total package power. Defined as $(T_{\text{CASE}} - T_{\text{JUNCTION}}) / \text{Total Package Power}$. Also referred to as Ψ_{JS} .
Ψ_{SA}	Sink-to-ambient thermal characterization parameter. A measure of heatsink thermal performance using total package power. Defined as $(T_{\text{SINK}} - T_{\text{JUNCTION}}) / \text{Total Package Power}$.
°C	Degrees in Celsius
CFM	Volumetric airflow rate in cubic feet per minute
in.	Inches
in. H ₂ O	Pressure drop measured in inches of water
LFM	Airflow velocity in linear feet per minute

Table 1. Definition of Terms (Sheet 2 of 2)

LV	Low Voltage designation for the processor SKUs offered with a lower VID.
PCB	Printed circuit board
T _{SINK}	Heatsink temperature measured on the underside of the heatsink base.
TIM	Thermal Interface Material – the thermally conductive compound between the heatsink and processor case. This material fills air gaps and voids, and enhances spreading of the heat from the case to the heatsink.
U	A unit of measure used to define server rack spacing height. 1U is equal to 1.75 inches, 2U equals 3.50 inches, etc.
W	Watt

1.3 Reference Documents

The reader of this specification should also be familiar with material and concepts presented in the following documents:

- Intel® Mobile Processor Micro-FCPGA Socket (mPGA479M) Design Guidelines
- Intel® Core™ Duo processor and Intel® Core™ Solo processor on 65 nm process Datasheet

Contact your Intel field sales representative for more information and to obtain these documents.

1.4 Thermal Design Tool Availability

Intel provides thermal simulation models of the device and a thermal model user’s guide to aid system designers in simulating, analyzing, and optimizing thermal solutions in an integrated, system-level environment. The models are for use with commercially available Computational Fluid Dynamics (CFD)-based thermal analysis tools including Flotherm* (version 3.1 or higher) by Flomerics, Inc. or Icepak* by Fluent, Inc. Contact your Intel representative to order the thermal models and associated user’s guides.

Package Information

2

The Intel® Core™ Duo processor utilizes a 35 x 35 mm, 478-pin micro-FCPGA package (refer to [Figure 2, “Micro-FCPGA Package \(Sheet 1 of 2\)” on page 11](#) and [Figure 3, “Micro-FCPGA Package \(Sheet 2 of 2\)” on page 12](#)) and the 479-ball micro-FCBGA package (refer to [Figure 4, “Micro-FCBGA Package \(Sheet 1 of 2\)” on page 13](#) and [Figure 5, “Micro-FCBGA Package \(Sheet 2 of 2\)” on page 14](#)). The data is provided for reference only. Refer to the device’s most recent datasheet for up-to-date information. In the event of conflict, the device’s datasheet supersedes data shown in these figures. The Intel Core Duo processor LV is only available in the micro-FCBGA package.

The processors in the micro-FCPGA package connect to the motherboard through a 479-pin surface mount, zero insertion force (ZIF) socket. A description of the socket can be found in the [Intel® Mobile Processor Micro-FCPGA Socket \(mPGA479M\) Design Guidelines](#).

The Micro-FCBGA package incorporates land-side capacitors. The land-side capacitors are electrically conductive, care should be taken to avoid contacting the capacitors with any other electrically conductive materials. Doing so may short the capacitors and possibly damage the device or render it inactive.

The processor package has mechanical load limits that are specified in the processor datasheet. These load limits should not be exceeded during heatsink installation, removal, mechanical stress testing, or standard shipping conditions. The heatsink mass can also add additional dynamic compressive load to the package during a mechanical shock event. Amplification factors due to the impact force during shock must be taken into account in dynamic load calculations. The total combination of dynamic and static compressive load should not then exceed the processor datasheet compressive dynamic load specification during a vertical shock. It is not recommended to use any portion of the processor substrate as a mechanical reference or load bearing surface in either static or dynamic compressive load conditions.

Figure 4. Micro-FCBGA Package (Sheet 1 of 2)

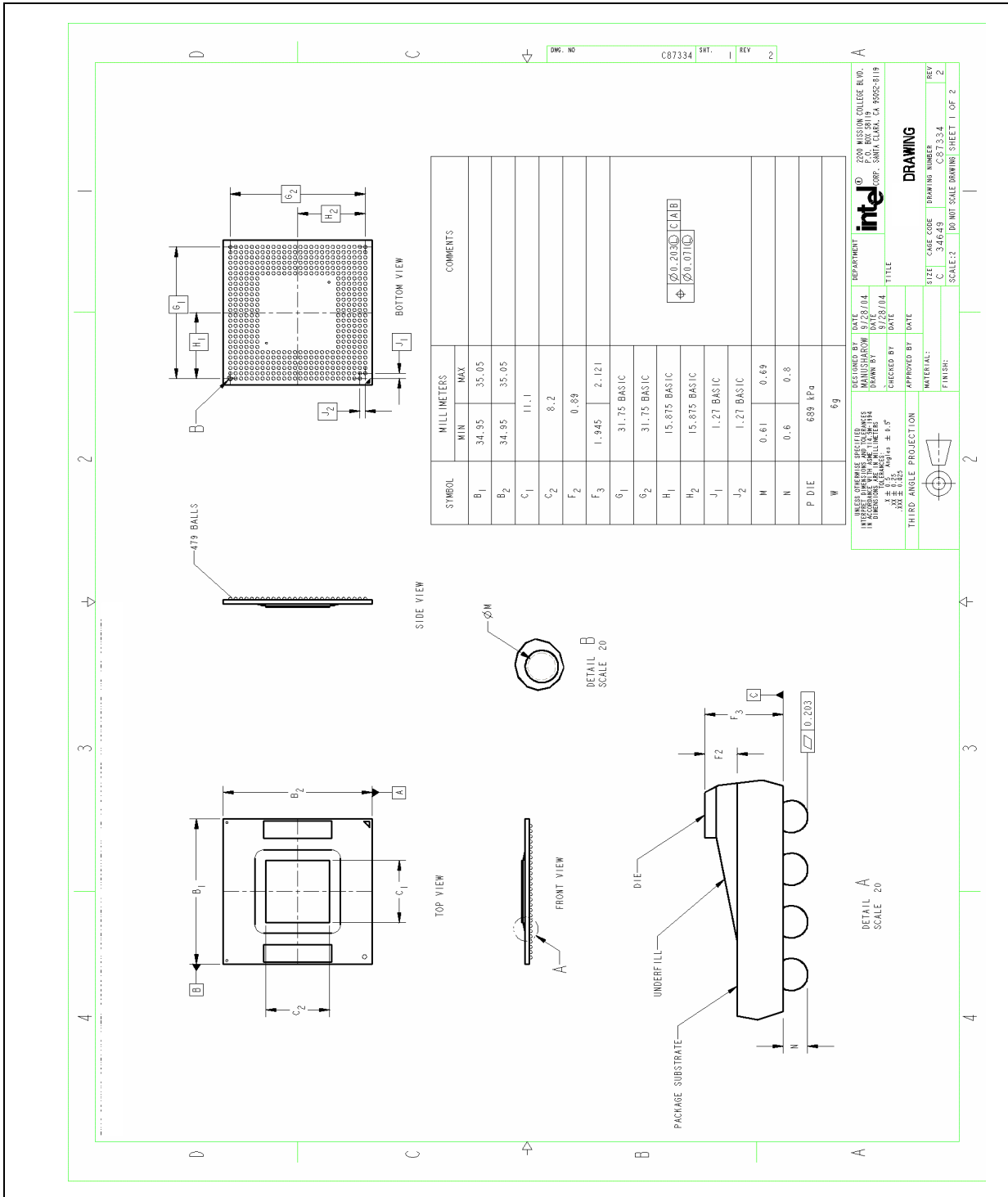
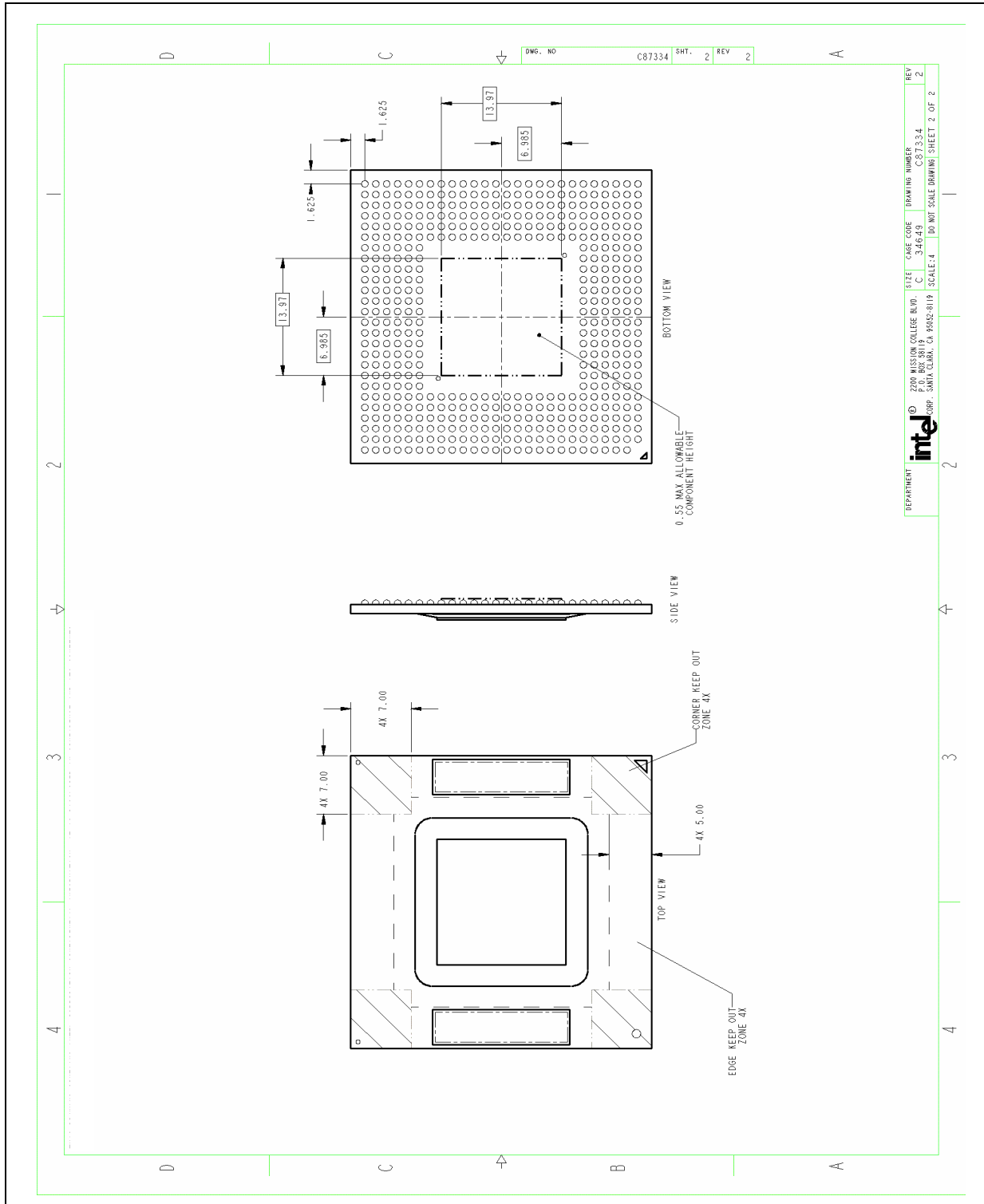

Figure 5. Micro-FCBGA Package (Sheet 2 of 2)



Thermal Specifications

3

3.1 Thermal Design Power

The Thermal Design Power (TDP) specification is listed in [Table 2](#). Heat transfer through the micro-FCBGA, micro-FCPGA package and socket via the base board is negligible. The cooling capacity without a thermal solution is also minimal, so **Intel requires the use of a heatsink for all usage conditions.**

3.2 Maximum Allowed Component Temperature

The device must maintain a maximum temperature at or below the value specified in [Table 2](#). The thermal solution is required to meet the temperatures specification while dissipating the Thermal Design Power. Section Thermal Metrology includes guidelines for accurately measuring the device temperature.

Table 2. Thermal Specifications for the Intel® Core™ Duo processor

CPU	# of cores	Processor #	Frequency (GHz)	TDP (W)	TJ-MAX (°C)	TJ-MIN (°C)
Intel® Core™ Duo processor	2	T2500	2.0	31.0	100	0
Intel® Core™ Duo processor LV	2	L2400	1.66	15.0	100	0

Mechanical Specifications

4

4.1 Package Mechanical Requirements

The package level requirements are detailed in Section Package Information including the maximum pressure allowed on the bare die package. More information may be available in the processor's Datasheet.

4.2 Package Keep Out Zones Requirements

The heatsink must not touch the package in the areas shown in [Figure 2, “Micro-FCPGA Package \(Sheet 1 of 2\)” on page 11](#) and [Figure 4, “Micro-FCBGA Package \(Sheet 1 of 2\)” on page 13](#). The heatsink should include a means to prevent the heatsink from forming an electrical short with the capacitors placed on the top side of the package. The reference thermal solutions include z-stops machined into the base of the heatsink. The z-stops prevent the heatsink from inadvertently tilting when installed. Other methods are suitable including using electrically insulated gasket material at the base of the heatsink.

4.3 Board Level Keep Out Zone Requirements

A general description of the keep-out zones and mounting hole pattern for the reference thermal solutions are shown in [Figure 6](#) and [Figure 7](#). Detailed drawings for the PCB keep out zones are contained in the appendix.

Components placed between the underside of the heatsink and motherboard cannot exceed 4.75 mm in height when using heatsinks that extend beyond the socket envelope shown in [Figure 2](#) for the micro-FCPGA package.

Figure 6. Primary Side Keep Out Zone Requirements— Micro-FCPGA

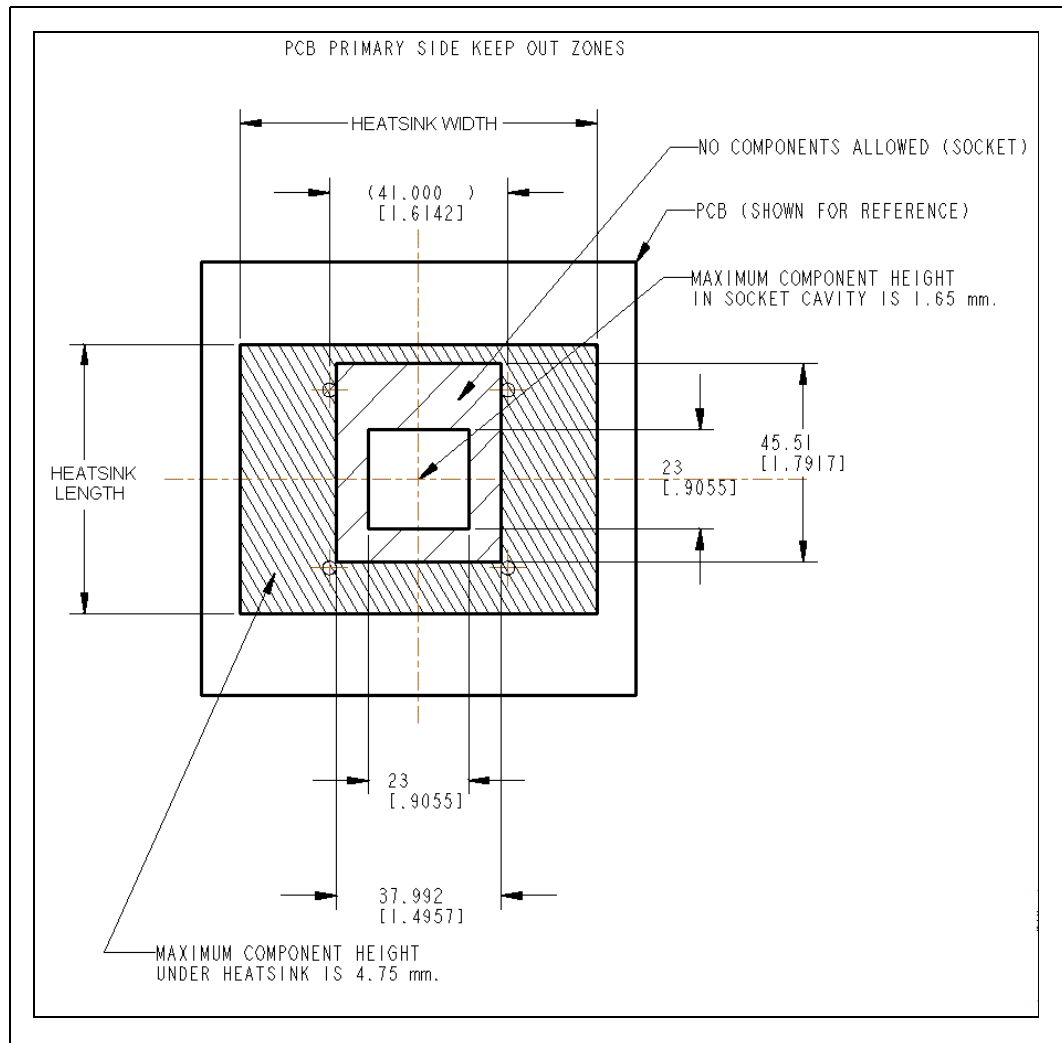

Notes:

1. Dimension in millimeters [inches].

Figure 7. Primary Side Keep Out Zone Requirements— Micro-FCBGA

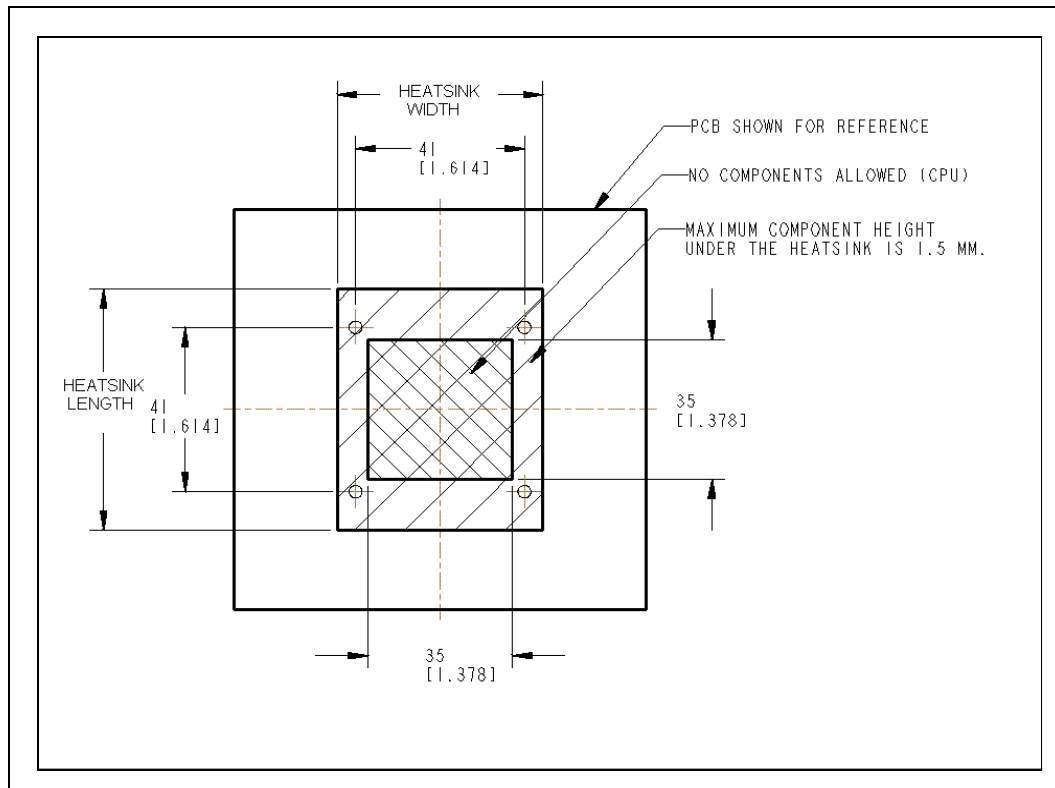

Notes:

1. Dimension in millimeters [inches].

Figure 8. Secondary Side Keep Out Zone Requirements

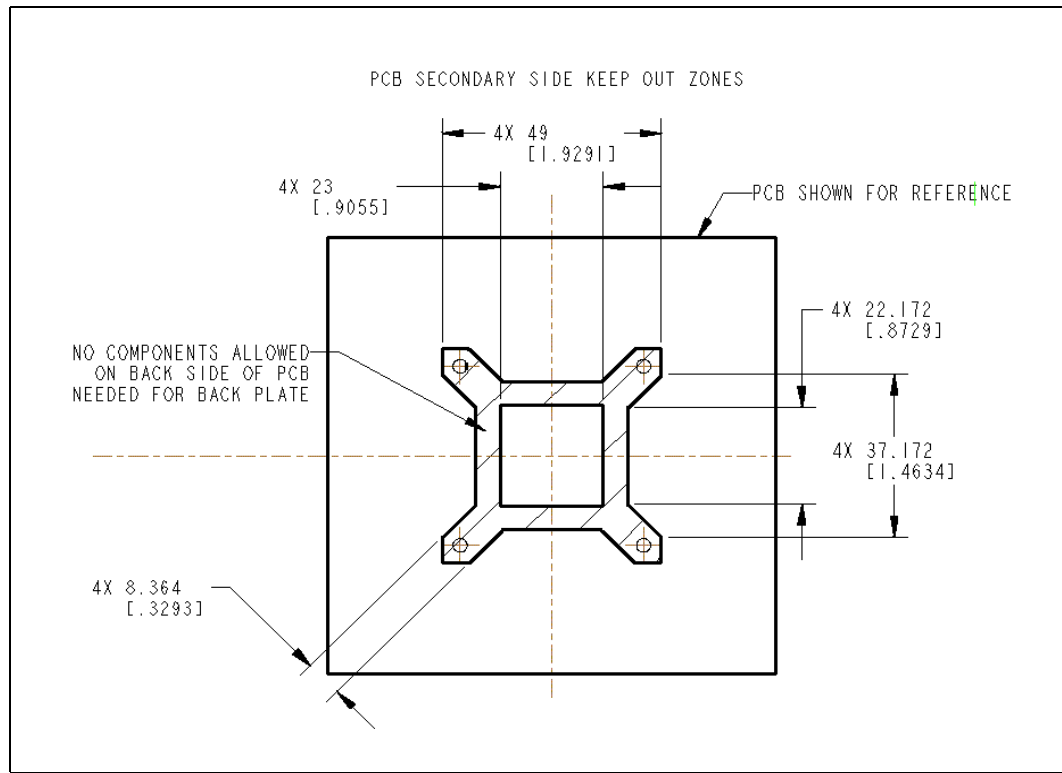

Notes:

1. Dimension in millimeters [inches].

Thermal Solution Requirements

5

5.1 Characterizing the Thermal Solution Requirement

The idea of a thermal characterization parameter, Ψ (“psi”), is a convenient way to characterize the performance needed for the thermal solution and to compare thermal solutions in identical situations (i.e., heating source, local ambient conditions, etc.). A thermal characterization parameter is convenient in that it is calculated using total package power, whereas actual thermal resistance, θ (theta), is calculated using actual power dissipated between two points. Measuring actual power dissipated into the heatsink is difficult, since some of the power (although a very minimal amount) is dissipated via heat transfer into the socket, board and surrounding air.

The junction-to-local ambient thermal characterization parameter (Ψ_{JA}) is used as a measure of the thermal performance of the overall thermal solution. It is defined by the following equation, and measured in units of °C/W:

Equation 1. Junction-to-Local Ambient Thermal Characterization Parameter (Ψ_{JA})

$$\Psi_{JA} = \frac{T_J - T_{LA}}{TDP}$$

Again:

Ψ_{JA} = Junction-to-local ambient thermal characterization parameter (°C/W)

$T_{JUNCTION\ MAX}$ = Maximum allowed device temperature (°C)

T_{LA} = Local ambient temperature near the device (°C) (see Section Thermal Metrology for measurement guidelines)

TDP = Thermal Design Power (W), assumes all power dissipates through the top surface of the device

The junction-to-local ambient thermal characterization parameter, Ψ_{JA} , is comprised of Ψ_{JS} , which includes the thermal interface material thermal characterization parameter, and of Ψ_{SA} , the sink-to-local ambient thermal characterization parameter:

Equation 2. Junction-to-Local Ambient Thermal Characterization Parameter

$$\Psi_{JA} = \Psi_{JS} + \Psi_{SA}$$

Where:

Ψ_{JS} (Ψ_{TIM}) = Thermal characterization parameter from junction-to-sink, this also includes thermal resistance of the thermal interface material (°C/W)

Ψ_{SA} = Thermal characterization parameter from sink-to-local ambient (°C/W)

Ψ_{TIM} is strongly dependent on the thermal conductivity and thickness of the TIM between the heatsink and device package.

Ψ_{SA} is a measure of the thermal characterization parameter from the bottom of the heatsink to the local ambient air. Ψ_{SA} is dependent on the heatsink material, thermal conductivity, and geometry. It is also strongly dependent on the air velocity through the fins of the heatsink. Figure 9 illustrates the combination of the different thermal characterization parameters.

Figure 9. Processor Thermal Characterization Parameter Relationships

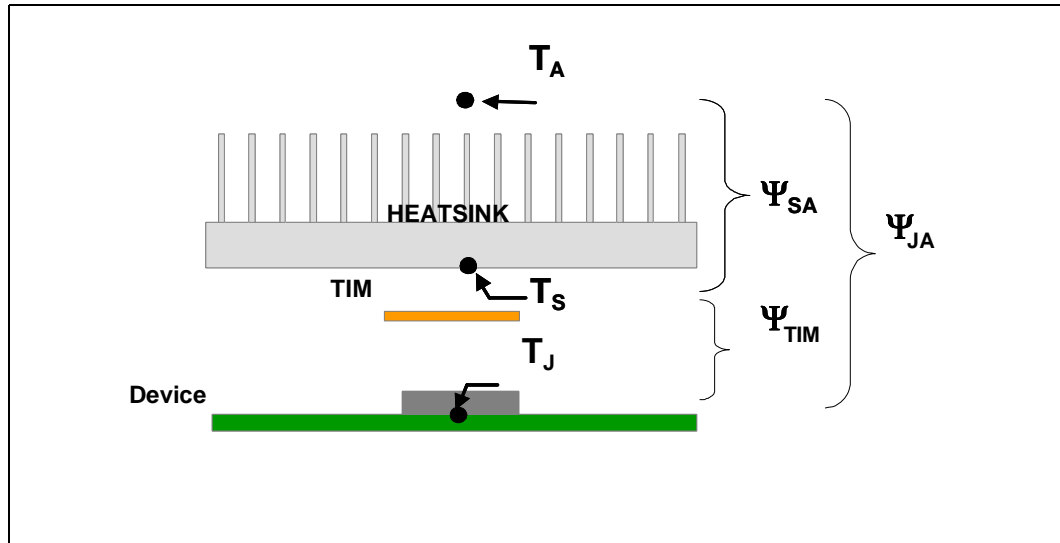

5.1.1 Calculating the Required Thermal Performance for the Intel® Core™ Duo processor LV

The cooling performance, Ψ_{JA} , is then defined using the thermal characterization parameter:

- Define a target component temperature $T_{JUNCTION}$ and corresponding TDP.
- Define a target local ambient temperature, T_{LA} .

The following provides an illustration of how one might determine the appropriate performance targets.

Assume:

- TDP = 15.0 W and $T_{JUNCTION} = 100^\circ\text{C}$
- Local processor ambient temperature, $T_{LA} = 55^\circ\text{C}$.

Then the following could be calculated using Equation 1 for the given processor frequency:

$$\Psi_{JA} = \frac{T_J - T_{LA}}{TDP} = \frac{100 - 55}{15.0} = 3.00 \text{ } ^\circ\text{C}/\text{W}$$

To determine the required heatsink performance, a heatsink solution provider would need to determine Ψ_{CA} performance for the selected TIM and mechanical load configuration. If the heatsink solution were designed to work with a TIM material performing at $\Psi_{TIM} \leq 1.0 \text{ }^\circ\text{C/W}$, solving from Equation 2, the performance of the heatsink required is:

$$\Psi_{SA} = \Psi_{CA} - \Psi_{TIM} = 3.00 - 1.00 = 2.00 \text{ }^\circ\text{C/W}$$

If the local processor ambient temperature is relaxed to 45°C , the same calculation can be carried out to determine the new case-to-ambient thermal resistance:

$$\Psi_{JA} = \frac{T_J - T_{LA}}{TDP} = \frac{100 - 45}{15.0} = 3.667 \text{ }^\circ\text{C/W}$$

It is evident from the above calculations that a reduction in the local ambient temperature has a significant effect on the junction-to-ambient thermal resistance requirement. This effect can contribute to a more reasonable thermal solution including reduced cost, heatsink size, heatsink weight, or a lower system airflow rate.

Table 3 summarizes the thermal budget required to adequately cool the Intel® Core™ on 65 nm process processors. Since the data is based on air data at sea level, a correction factor would be required to estimate the thermal performance at other altitudes.

Table 3. Required Heatsink Thermal Performance (Ψ_{JA})

Device	Frequency (GHz)	TDP (W)	Ψ_{JA} ($^\circ\text{C/W}$) at $T_{LA} = 40^\circ\text{C}^{1,2}$	Ψ_{JA} ($^\circ\text{C/W}$) at $T_{LA} = 55^\circ\text{C}^{1,2}$
Intel® Core™ Duo processor	2.0	31.0	1.94	1.45
Intel® Core™ Duo processor LV	1.66	15.0	4.00	3.00

Notes:

- T_{LA} is defined as the local (internal) ambient temperature measured approximately 1" upstream from the device.
- Ψ_{JA} is determined by $(T_{JUNCTION} - T_{LA})/TDP$, so this value will change if any parameter changes.

Reference Thermal Solution

6

Intel has developed reference thermal solutions designed to meet the cooling needs of embedded form factor applications. This chapter describes the overall requirements for the reference thermal solution including critical-to-function dimensions, operating environment, and verification criteria. This document details solutions that are compatible with the CompactPCI*, AdvancedTCA*, and Server System Infrastructure (1U and larger) form factors.

The heatsinks are attached to the board using a screw, spring and backplate assembly. The heatsink uses the fastener assembly (refer to [Section 6.4](#)) to mount to the PCB. Detailed drawings of this heatsink are provided in [Appendix B, “Mechanical Drawings”](#).

[Figure 10, “Compact PCI* Reference Heatsink Assembly”](#) on [page 24](#) illustrates an example of the thermal solution assembly. Full mechanical drawings of the thermal solutions and the corresponding heatsink clip are provided in [Appendix B, “Mechanical Drawings”](#). [Appendix A, “Thermal Solution Component Suppliers”](#) contains vendor information for each thermal solution component.

6.1 CompactPCI* Reference Heatsink

The reference thermal solution compatible with the CompactPCI form factor is designed assuming a maximum ambient temperature (as measured outside the chassis) of 40° C with a minimum volumetric airflow rate through each slot (CFM). Assuming these boundary conditions are met, the reference thermal solutions will meet the thermal specifications for the Intel[®] Core[™] Duo processor LV.

Note: The CompactPCI reference heatsink is not suitable for the 31 W Intel[®] Core[™] Duo processor.

6.1.1 Mechanical Design

The CompactPCI reference heatsink is shown in [Figure 10](#). The maximum component height for this form factor is 13.716 mm, so the maximum heatsink height is constrained to 10.79 mm. The heatsink uses the fastener assembly (refer to [Section 6.4](#)) to mount to the PCB. Detailed drawings of this heatsink are provided in [Appendix A, “Thermal Solution Component Suppliers”](#).

Figure 10. Compact PCI* Reference Heatsink Assembly

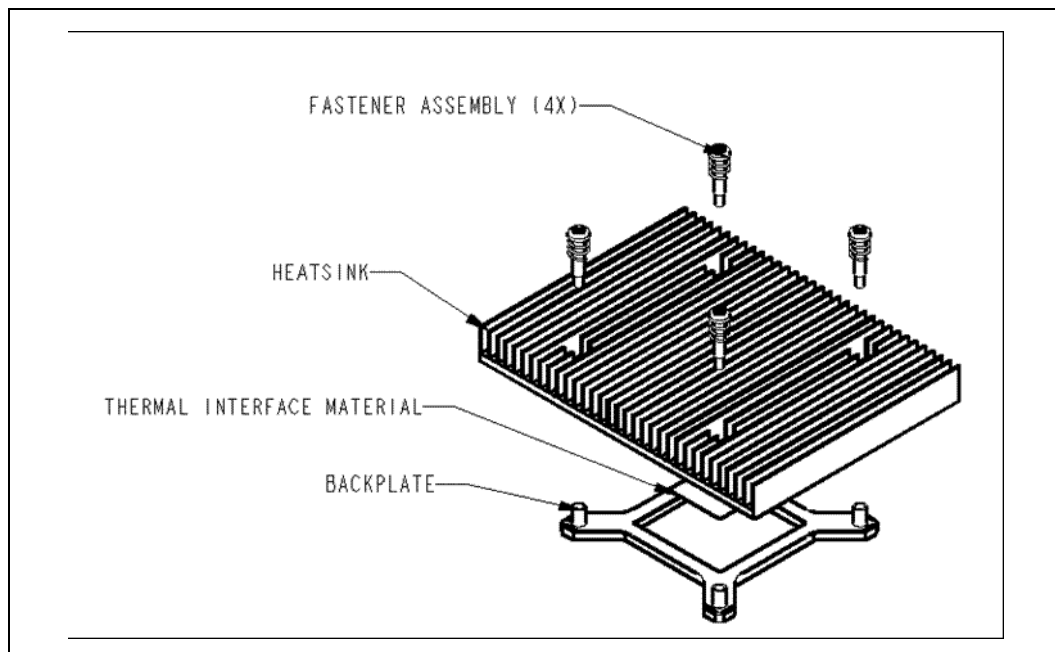

6.1.2 Keep Out Zone Requirements

The keep out zone requirements on the PCB to use this heatsink are detailed in [Appendix B, “Mechanical Drawings”](#). Because it extends beyond the footprint of the device, it is critical for board designers to allocate space for the heatsink.

6.1.3 Thermal Performance

The CompactPCI reference heatsink should be made from copper to achieve the necessary thermal performance. Based on the boundary conditions stated (ambient temperature = 40° C), the heatsink will meet the thermal performance needed to cool the Intel Core Duo processor LV in the CompactPCI form factor. The heatsink performance versus volumetric airflow rate is shown in [Figure 11](#).

The system integrator can make trade-offs to determine the best heatsink material to use based on usage conditions. For example, a higher ambient temperature might be considered with use of the copper heatsink.

Since the thermal performance for the copper heatsink at 1.0 CFM is 2.536 °C/W, the Intel Core Duo processor LV can be used up to a local ambient temperature of 62° C [$T_{LA} = 100^{\circ} \text{C} - (\Psi_{JA}) \times (\text{TDP})$].

Figure 11. CompactPCI* Heatsink Thermal Performance vs. Volumetric Airflow Rate

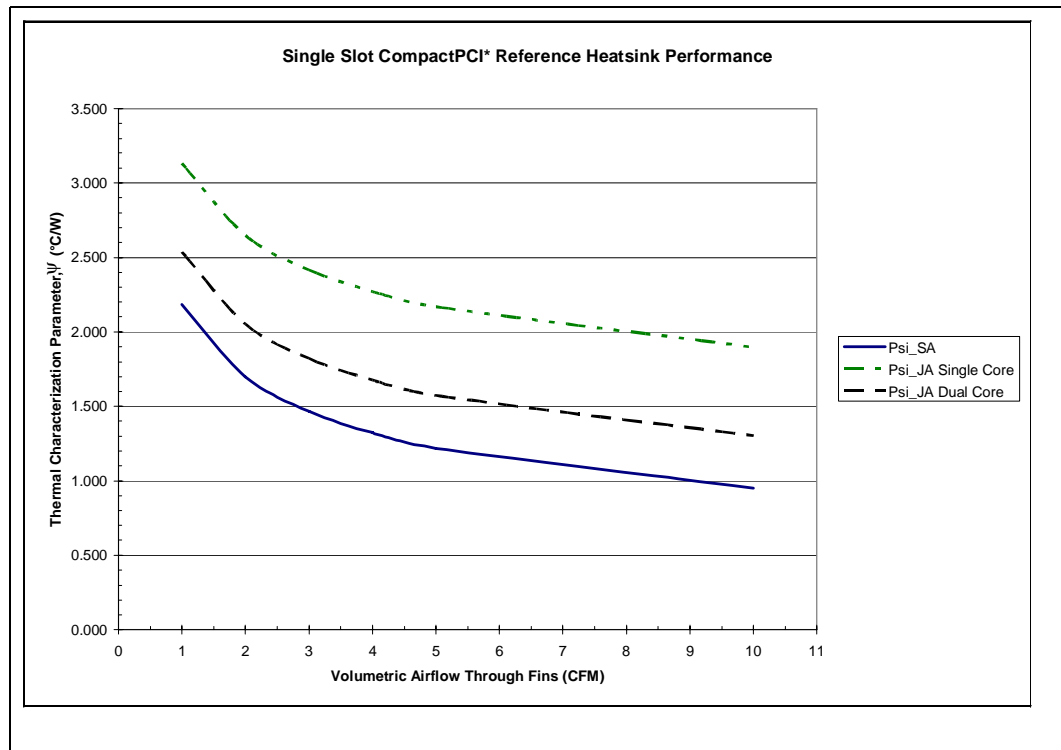

6.2 AdvancedTCA* Reference Heatsink

The reference thermal solution compatible with the AdvancedTCA form factor is designed assuming a maximum ambient temperature (as measured outside the chassis) of 40° C, with a minimum volumetric airflow rate through the ATCA slot of 25 CFM. Assuming these boundary conditions are met, the reference thermal solutions will meet the thermal specifications for all versions of the Intel Core Duo processor on 65 nm process.

6.2.1 Mechanical Design

The AdvancedTCA reference thermal solution is shown in Figure 12. The maximum component height for this form factor is 21.33 mm, so the maximum heatsink height is constrained to 16.27 mm. The heatsink uses the fastener assembly (refer to Section 6.4) to mount to the PCB. Detailed drawings of this heatsink are provided in Appendix B, “Mechanical Drawings”.

Figure 12. AdvancedTCA* Reference Heatsink Assembly

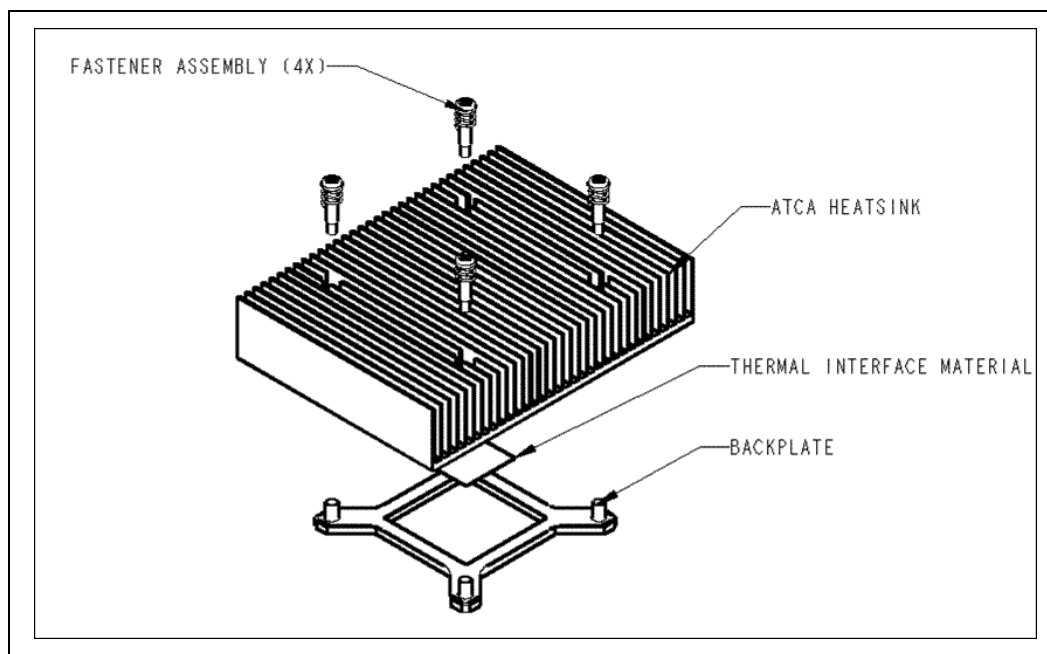

6.2.2 Keep Out Zone Requirements

The keep out zone requirements on the PCB to use this heatsink are detailed in [Appendix B, “Mechanical Drawings”](#). Because it extends beyond the footprint of the device, it is critical for the board designer to allocate space on the board for the heatsink.

6.2.3 Thermal Performance

The AdvancedTCA reference heatsink should be made from copper to achieve the necessary thermal performance. Based on the boundary conditions stated (ambient temperature = 40° C), the heatsink will meet the thermal performance needed to cool the Intel Core Duo processor on 65 nm process family in the AdvancedTCA form factor. [Figure 13](#) shows the heatsink performance versus volumetric airflow rate.

The system integrator can make trade-offs to determine the best heatsink material to use based on usage conditions. For example, a higher ambient temperature might be considered with use of the copper heatsink. Since the thermal performance for the copper heatsink at 5 CFM is 1.45 °C/W, the standard voltage Intel Core Duo processor can be used up to a local ambient temperature of 55° C [$T_{LA} = 100^{\circ} \text{C} - (\Psi_{JA}) \times (\text{TDP})$].

Figure 13. AdvancedTCA* Heatsink Thermal Performance vs. Volumetric Airflow Rate

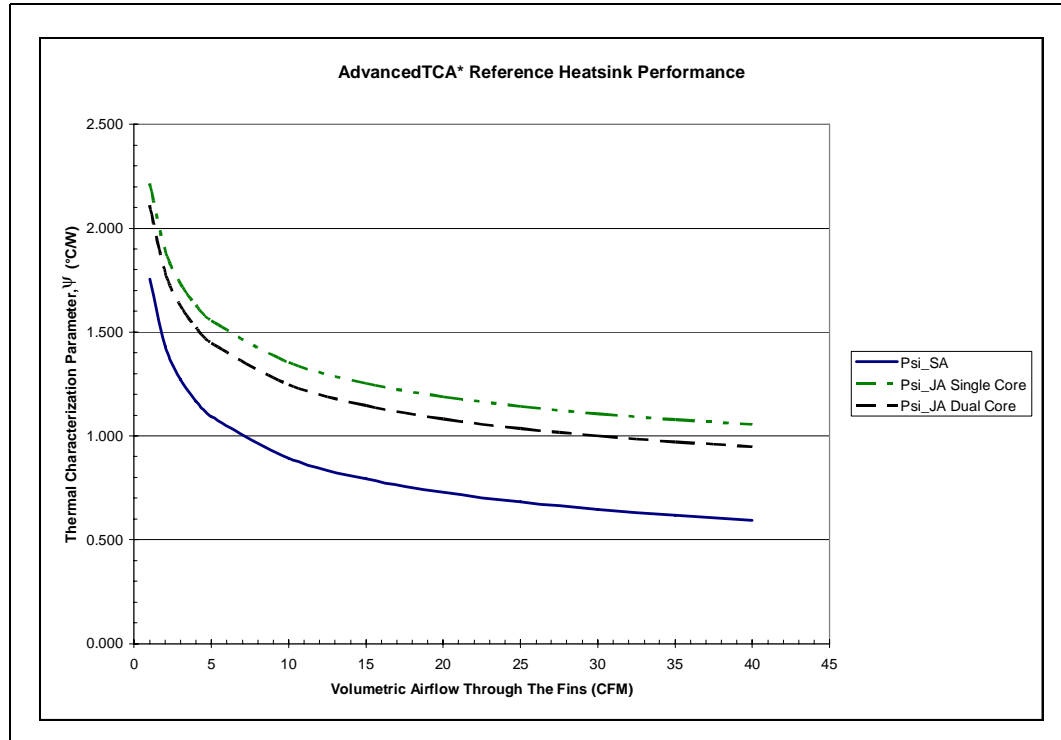

6.3 1U+ Reference Heatsink

The reference thermal solution compatible with the 1U and larger form factor is designed assuming a maximum ambient temperature (as measured outside the chassis) of 40° C with a minimum volumetric airflow rate through the heatsink fins of 4.0 CFM. Assuming these boundary conditions are met, the reference thermal solutions will meet the thermal specifications for the entire Intel Core Duo processor on 65 nm process family.

6.3.1 Mechanical Design

The 1U reference thermal solution is shown in Figure 14. The maximum heatsink height is constrained to 27 mm. The heatsink uses the fastener assembly (refer to Section 6.4) to mount to the PCB. Detailed drawings of this heatsink are provided in Appendix B, “Mechanical Drawings”.

Figure 14. 1U Reference Heatsink Assembly

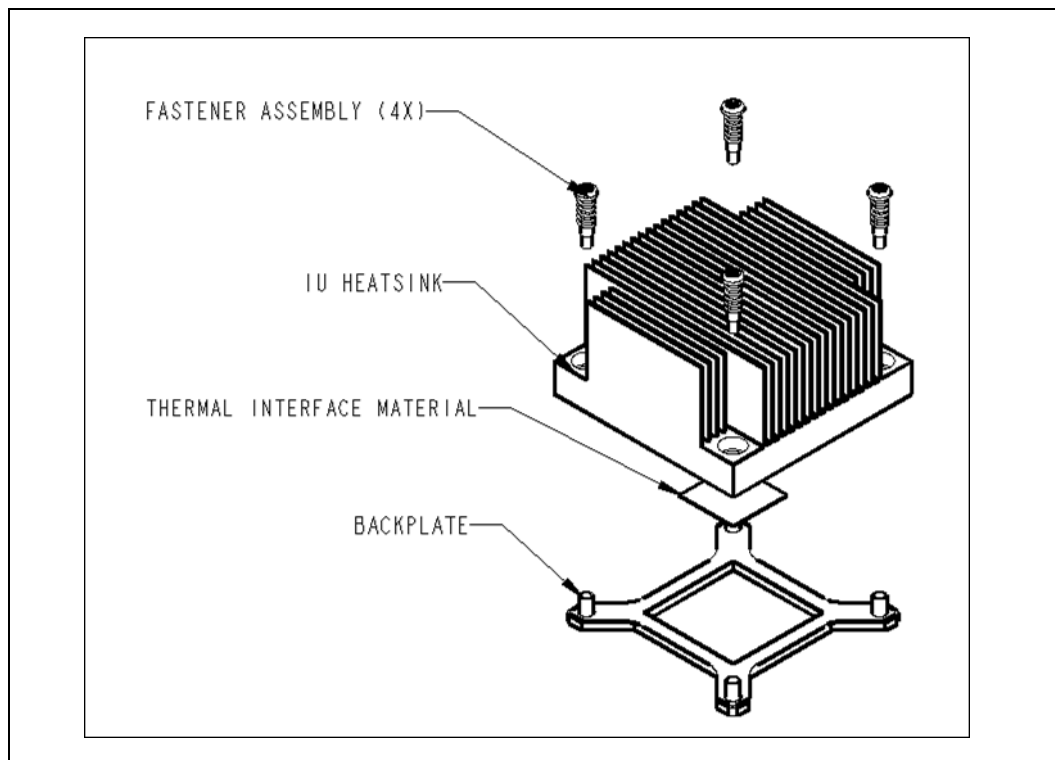

6.3.2 Keep Out Zone Requirements

The keep out zone requirements on the PCB to use this heatsink are detailed in [Appendix B, “Mechanical Drawings”](#). Because it extends beyond the footprint of the device, it is critical for board designers to allocate space for the heatsink.

6.3.3 Thermal Performance

The 1U reference heatsink should be made from copper to achieve the necessary thermal performance. Based on the boundary conditions stated ($T_{\text{ambient}} = 40^{\circ}\text{C}$), the heatsink will meet the thermal performance needed to cool the entire Intel Core Duo processor on 65 nm process family in the 1U form factor. Heatsink performance versus volumetric airflow rate is shown in [Figure 15](#).

The system integrator can make trade-offs to determine the best heatsink material to use based on usage conditions. For example, a higher ambient temperature might be considered with use of the copper heatsink. Since the thermal performance for the copper heatsink at 4.0 CFM is 1.357°C/W , the standard voltage Intel Core Duo processor can be used up to a temperature of 58°C [$T_{\text{LA}} = 100^{\circ}\text{C} - (\Psi_{\text{JA}}) \times (\text{TDP})$].

Figure 15. 1U Heatsink Thermal Performance vs. Volumetric Airflow Rate

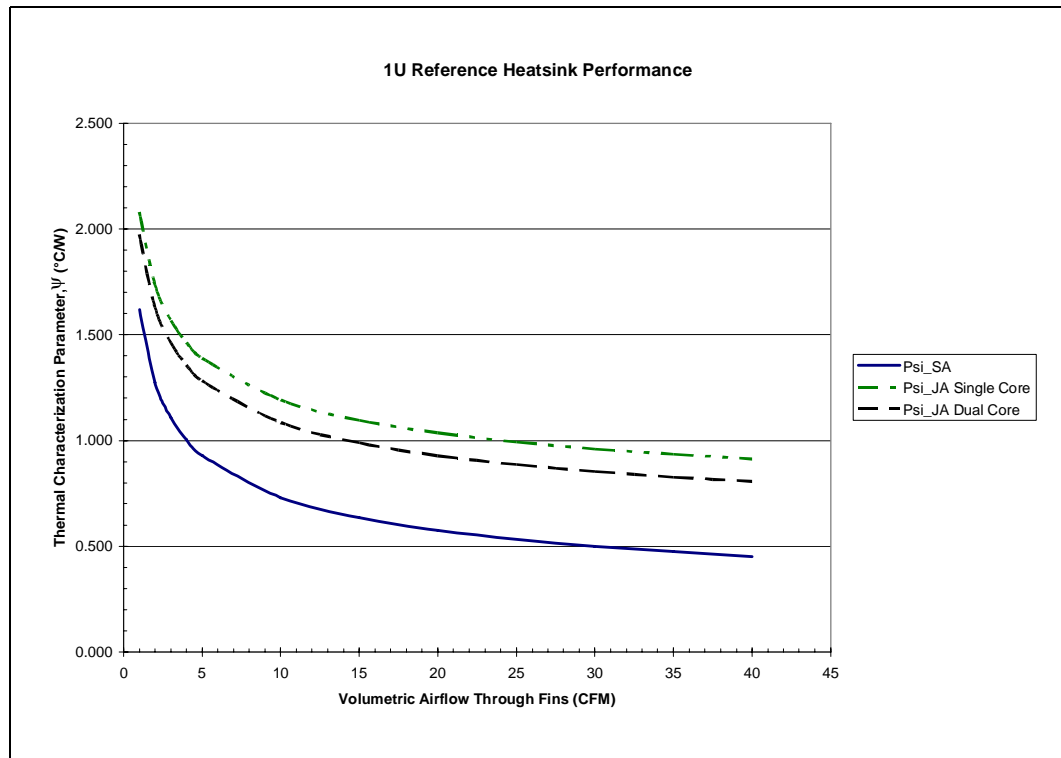

6.4 Heatsink Fastener Assembly

The reference solutions use a screw, spring, and back plate assembly to attach the heatsink to the PCB. The fastener assembly used on the reference heatsink must apply the load conditions described in Section Package Mechanical Requirements. The fastener assembly must comply with all of the keep out zone requirements described in this document, and should not degrade the thermal performance of the reference heatsinks. Finally the fastener assembly should be designed to meet the reliability guidelines described in Section Reliability Guidelines.

6.5 Thermal Interface Material (TIM)

The thermal interface material provides improved conductivity between the die and heatsink. It is important to understand and consider the impact of the interface between the die and heatsink base to the overall thermal solution. Specifically, the bond line thickness, interface material area, and interface material thermal conductivity must be selected to optimize the thermal solution.

It is important to minimize the thickness of the thermal interface material (TIM), commonly referred to as the bond line thickness. A large gap between the heatsink base and the die yields a greater thermal resistance. The thickness of the gap is determined by the flatness of both the heatsink base and the die, plus the thickness of the thermal interface material, and the clamping force applied by the heatsink attachment method. To ensure proper and consistent thermal performance, the TIM and application process must be properly designed.

Thermal interface materials have thermal impedance (resistance) that will increase over time as the material degrades. It is important for thermal solution designers to take this increase in impedance into consideration when designing a thermal solution. It is recommended that system integrators work with TIM suppliers to determine the performance of the desired thermal interface material. If system integrators wish to maintain maximum thermal solution performance, the TIM could be replaced during standard maintenance cycles.

The reference thermal solution uses Honeywell* PCM45F. Alternative materials can be used at the user's discretion. Regardless, the entire heatsink assembly, including the heatsink, and TIM (including attach method), must be validated together for specific applications.

6.6 Heatsink Orientation

All of the heatsinks were designed to maximize the available space within the volumetric keep out zone and their respective form factor limitations. These heatsinks must be oriented in a specific direction relative to the processor keep out zone and airflow. In order to use these designs, the processor must be placed on the PCB in an orientation so the heatsink fins will be parallel to the airflow. [Figure 16](#) illustrates this orientation.

Figure 16. Heatsink Orientation Relative to Airflow Direction

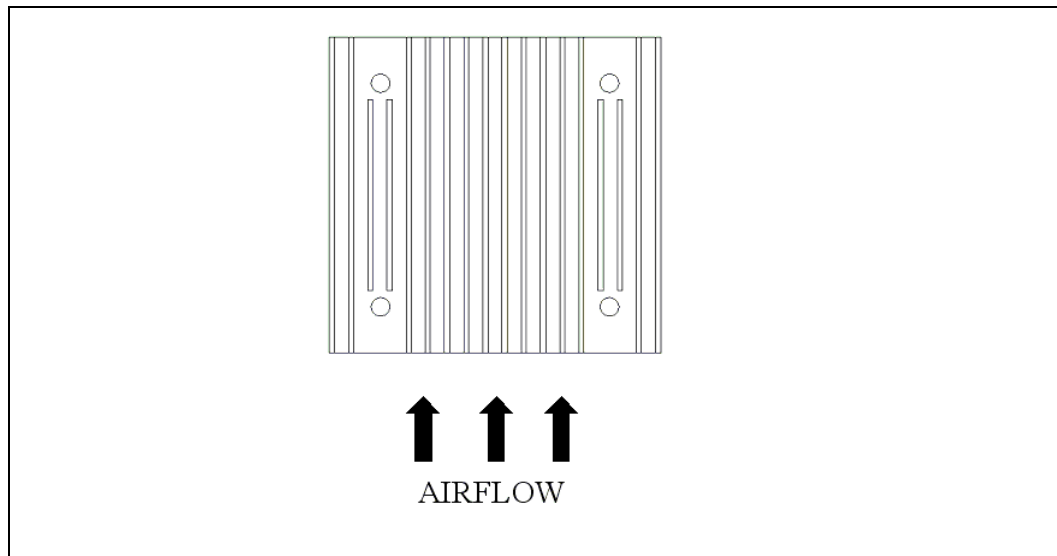

Thermal Metrology

7

The system designer must make temperature measurements to accurately determine the performance of the thermal solution. Validation of the processor's thermal solution should be done using a thermal test vehicle (TTV). The TTV allows for an accurate junction temperature measurement as well as input power control. For more information contact your Intel field sales representative.

In addition, the processor's heatsink should be verified in a system environment. Intel has established guidelines for techniques to measure the component temperature. Section Die Temperature Measurements provides guidelines on how to accurately measure the component temperature. Section Power Simulation Software contains information on running an application program that will emulate anticipated maximum thermal design power.

7.1 Die Temperature Measurements

The component T_{JUNCTION} must be maintained at or below the maximum temperature specification as noted in Section Maximum Allowed Component Temperature. The best way to measure die temperature is to use the Digital Thermal Sensor as described in the processor's datasheet. Refer to the processor datasheet for more information on the DTS.

The legacy on-board thermal diode is not recommended for performing heatsink validation. The thermal diode is suitable for long term trending data, but is not a reliable indicator of the processor's temperature.

7.2 Power Simulation Software

The power simulation software is a utility designed to dissipate the thermal design power on a processor. To assess the thermal performance of the processor thermal solution under "worst-case realistic application" conditions, Intel is developing a software utility that operates the processor at near worst-case power dissipation.

The power simulation software should only be used to test customer thermal solutions at or near the thermal design power. For power supply current, please refer to each component's datasheet for the I_{CC} (Max Power Supply Current) specification. For information on how to obtain the maximum power program, contact your Intel field sales representative.

7.3 Additional Thermal Features

The Intel® Core™ Duo processor supports other thermal features including the Intel Thermal Monitor, PROCHOT#, FORCEPR#, and THERMTRIP# signal pins. Details for using these features are contained in the processor datasheet.

7.4 Local Ambient Temperature Measurement Guidelines

The local ambient temperature (T_{LA}) is the temperature of the ambient air surrounding the processor. For a passive heatsink, T_A is defined as the heatsink approach air temperature; for an actively cooled heatsink, it is the temperature of inlet air to the active cooling fan.

It is worthwhile to determine the local ambient temperature in the chassis around the processor to understand the effect it may have on the case temperature. T_{LA} is best measured by averaging temperature measurements at multiple locations in the heatsink inlet airflow. This method helps reduce error and eliminate minor spatial variations in temperature. The following guidelines are meant to enable accurate determination of the localized air temperature around the processor during system thermal testing.

7.4.1 Active Heatsink Measurements

- It is important to avoid taking measurements in the dead flow zone that usually develops above the fan hub and hub spokes. Measurements should be taken at four different locations uniformly placed at the center of the annulus formed by the fan hub and the fan housing to evaluate the uniformity of the air temperature at the fan inlet. The thermocouples should be placed approximately 3 mm to 8 mm [0.1 to 0.3 in] above the fan hub vertically and halfway between the fan hub and the fan housing horizontally as shown in [Figure 17](#) (avoiding the hub spokes).
- Using an open bench to characterize an active heatsink can be useful, and usually ensures more uniform temperatures at the fan inlet. However, additional tests that include a solid barrier above the test motherboard surface can help evaluate the potential impact of the chassis. This barrier is typically clear Plexiglas*, extending at least 100 mm [4 in.] in all directions beyond the edge of the thermal solution. Typical distance from the motherboard to the barrier is 81 mm [3.2 in.]. If a barrier is used, the thermocouple can be taped directly to the barrier with clear tape at the horizontal location as previously described, halfway between the fan hub and the fan housing.
- For even more realistic airflow, the motherboard should be populated with significant elements like memory cards, graphic card, and chipset heatsink. If a variable speed fan is used, it may be useful to add a thermocouple taped to the barrier above the location of the temperature sensor used by the fan to check its speed setting against air temperature. When measuring T_{LA} in a chassis with a live motherboard, add-in cards, and other system components, it is likely that the T_{LA} measurements will reveal a highly non-uniform temperature distribution across the inlet fan section.

Note: Testing an active heatsink with a variable speed fan can be done in a thermal chamber to capture the worst-case thermal environment scenarios. Otherwise, when doing a bench top test at room temperature, the fan regulation prevents the heatsink from operating at its maximum capability. To characterize the heatsink capability in the worst-case environment in these conditions, it is then necessary to disable the fan regulation and power the fan directly, based on guidance from the fan supplier.

7.4.2 Passive Heatsink Measurements

- Thermocouples should be placed approximately 13 mm to 25 mm [0.5 to 1.0 in] away from processor and heatsink as shown in [Figure 18](#).

- The thermocouples should be placed approximately 51 mm [2.0 in] above the baseboard. This placement guideline is meant to minimize the effect of localized hot spots from baseboard components. The height above the board may vary depending on the height of the thermal solution and form factor.

Figure 17. Measuring T_{LA} with an Active Heatsink

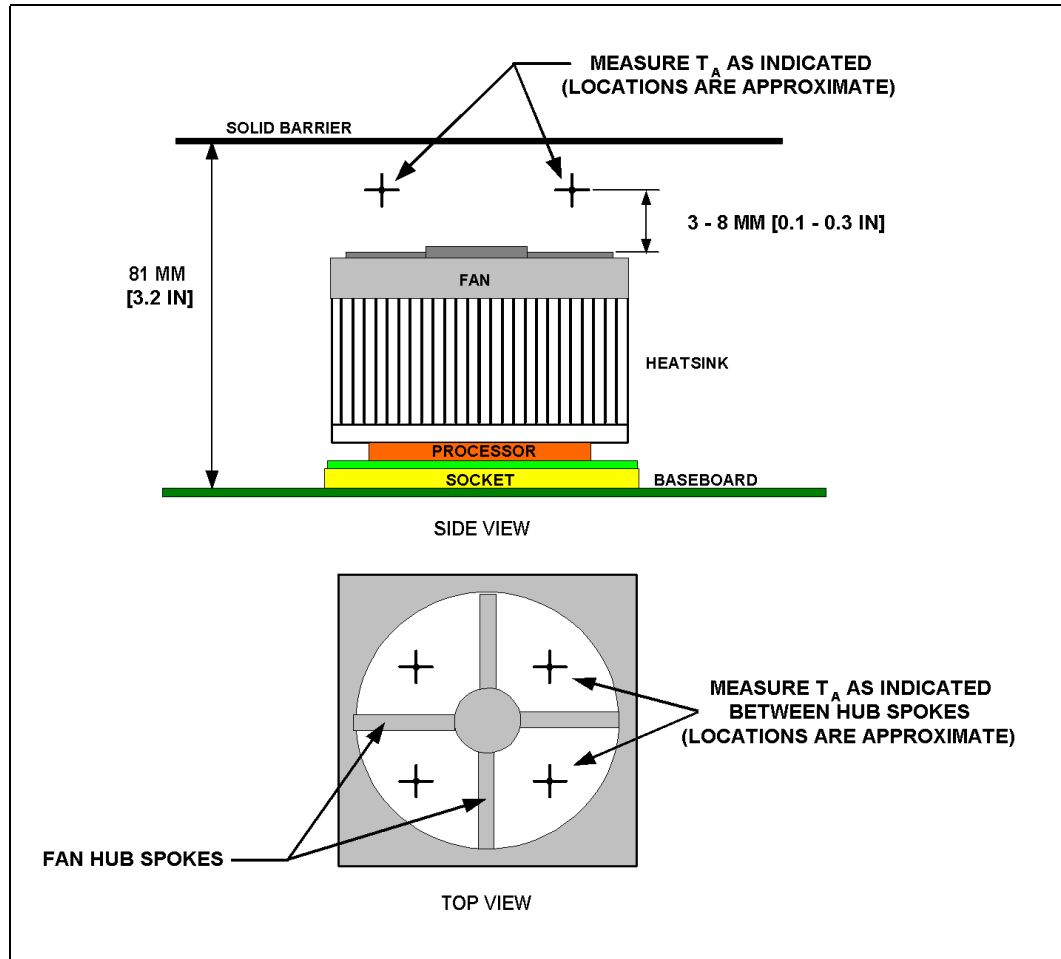

Note: Drawing not to scale.

Figure 18. Measuring T_{LA} with a Passive Heatsink

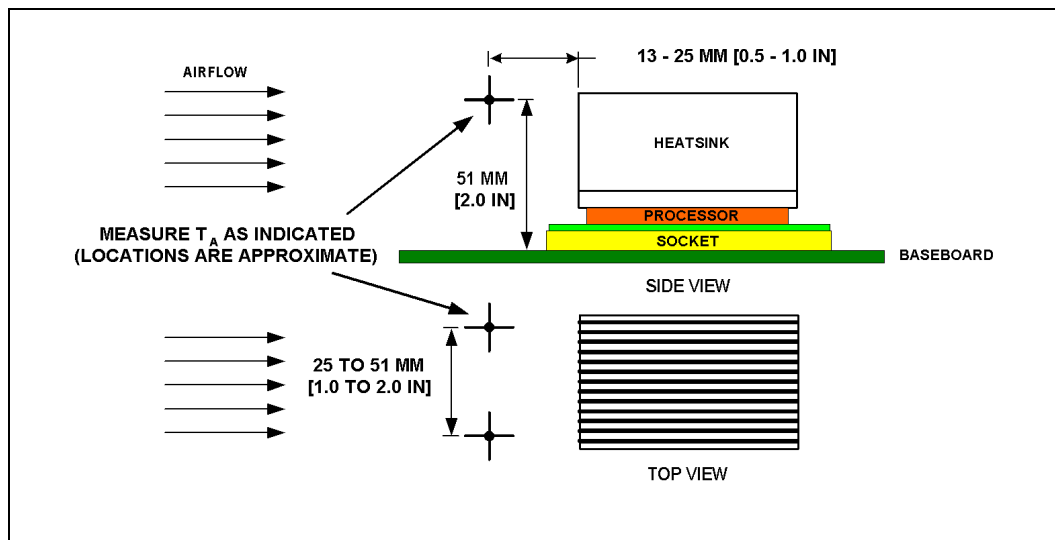

Note: Drawing not to scale.

Reliability Guidelines

8

Each motherboard, heatsink, and attach combination may vary the mechanical loading of the component. The user should carefully evaluate the reliability of the completed assembly prior to use in high volume. Some general recommendations are shown in the table below.

Table 4. Reliability Requirements

Test ¹	Requirement	Pass/Fail Criteria ²
Mechanical Shock	50 g, board level, 11 msec, 3 shocks/axis	Visual Check and Electrical Functional Test
Random Vibration	7.3 g, board level, 45 min/axis, 50 Hz to 2000 Hz	Visual Check and Electrical Functional Test
Temperature Life	85° C, 2000 hours total, checkpoints at 168, 500, 1000, and 2000 hours	Visual Check
Thermal Cycling	-5° C to +70° C, 500 cycles	Visual Check
Humidity	85% relative humidity, 55 °C, 1000 hours	Visual Check

Notes:

1. The above tests should be performed on a sample size of at least 12 assemblies from 3 lots of material.
2. Additional pass/fail criteria may be added at the discretion of the user.

Thermal Solution Component Suppliers

A

These vendors and devices are listed by Intel as a convenience to Intel's general customer base. Intel does not make any representations or warranties whatsoever regarding quality, reliability, functionality, or compatibility of these devices. This list and/or these devices may be subject to change without notice.

Note: The enabled components may not be currently available from all suppliers. Contact the supplier directly to verify availability.

Reference Heatsink

Part	Part Number	Contact Information
AdvancedTCA* Heatsink	ECC-00177-01-GP	Cooler Master* Wendy Lin wendy@coolermaster.com (510)770-8566 ext 211
CompactPCI* Heatsink	ECC-00178-01-GP	
1U+ Passive Heatsink	ECC-00179-01-GP	
Thermal Interface Material	PCM45F	Honeywell* Paula Knoll paula.knoll@honeywell.com (858) 279-2956

Mechanical Drawings

B

The table below lists the mechanical drawings included in this appendix.

Table 5. Mechanical Drawings

Description	Figure
AdvancedTCA* Reference Heatsink PCB Keep Out Zone Requirements (Sheet 1 of 2)	Figure 19
AdvancedTCA* Reference Heatsink PCB Keep Out Zone Requirements (Sheet 2 of 2)	Figure 20
AdvancedTCA* Reference Heatsink Assembly	Figure 21
AdvancedTCA* Reference Heatsink	Figure 22
CompactPCI* Reference Heatsink PCB Keep Out Zone Requirements (Sheet 1 of 2)	Figure 23
CompactPCI* Reference Heatsink PCB Keep Out Zone Requirements (Sheet 2 of 2)	Figure 24
CompactPCI* Reference Heatsink Assembly	Figure 25
CompactPCI* Reference Heatsink	Figure 26
1U Reference Heatsink PCB Keep Out Requirements (Sheet 1 of 2)	Figure 27
1U Reference Heatsink PCB Keep Out Requirements (Sheet 2 of 2)	Figure 28
1U Reference Heatsink Assembly	Figure 29
1U Reference Heatsink	Figure 30

Figure 19. AdvancedTCA* Reference Heatsink PCB Keep Out Zone Requirements (Sheet 1 of 2)

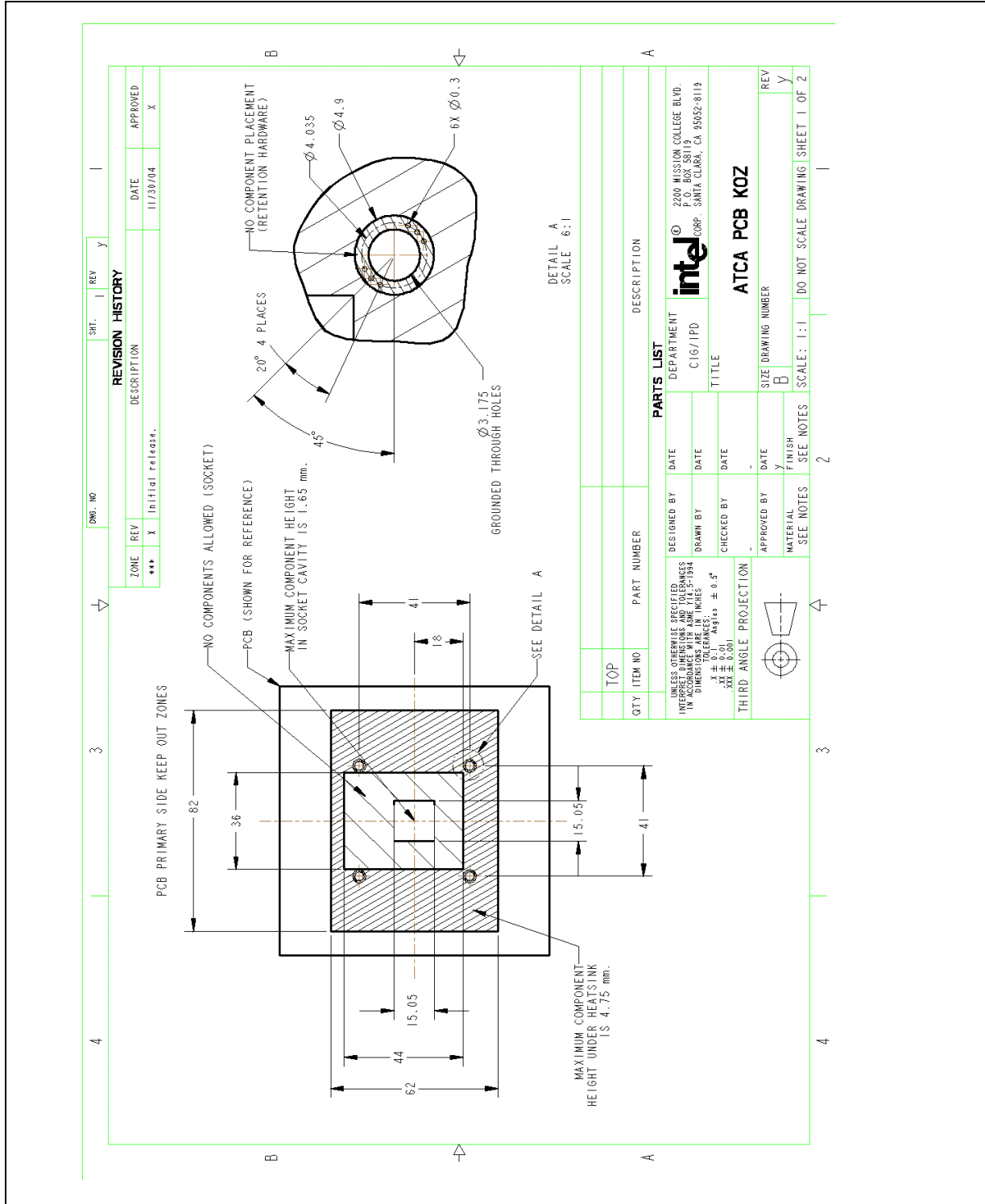

Figure 20. AdvancedTCA* Reference Heatsink PCB Keep Out Zone Requirements (Sheet 2 of 2)

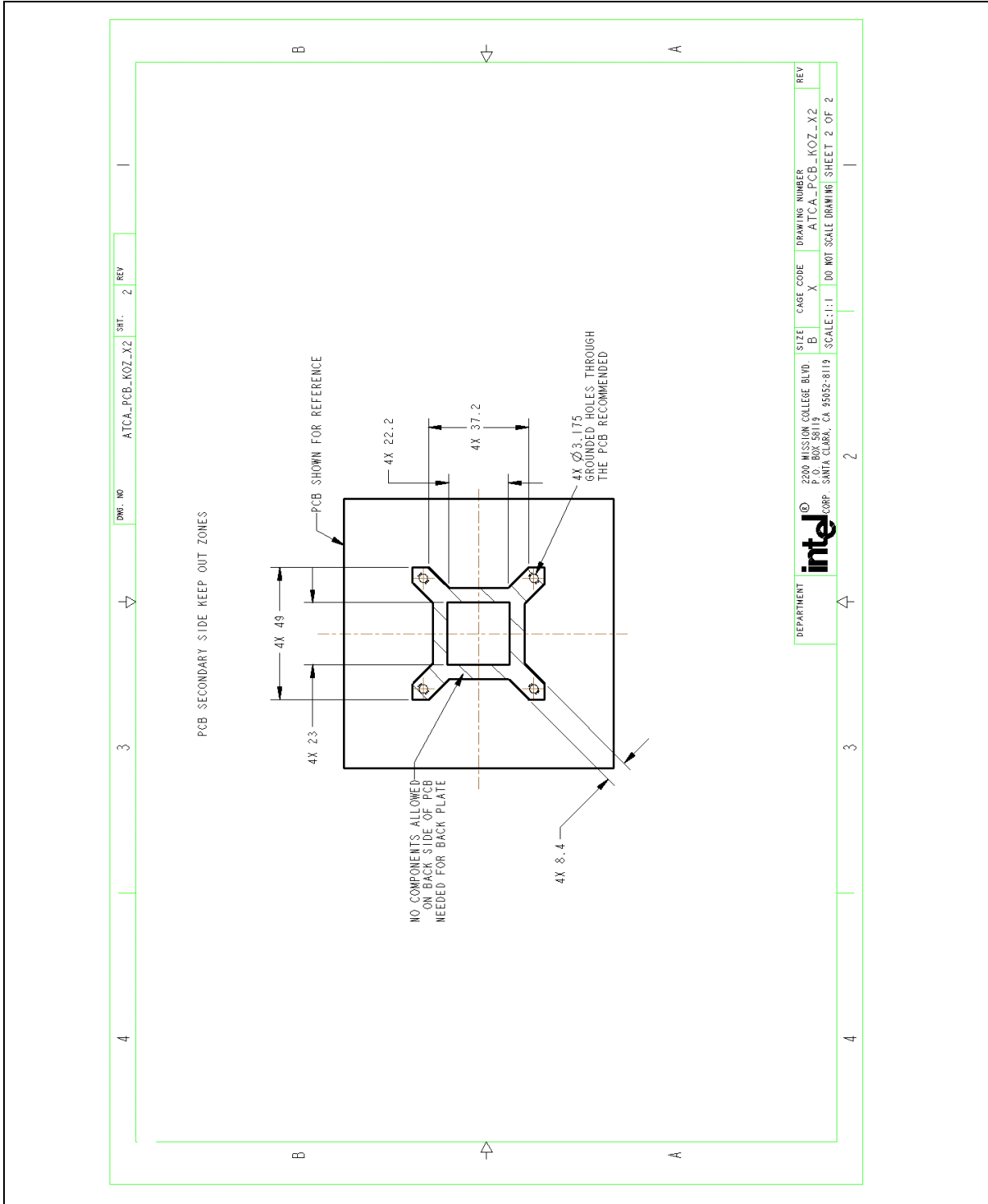

Figure 21. AdvancedTCA* Reference Heatsink Assembly

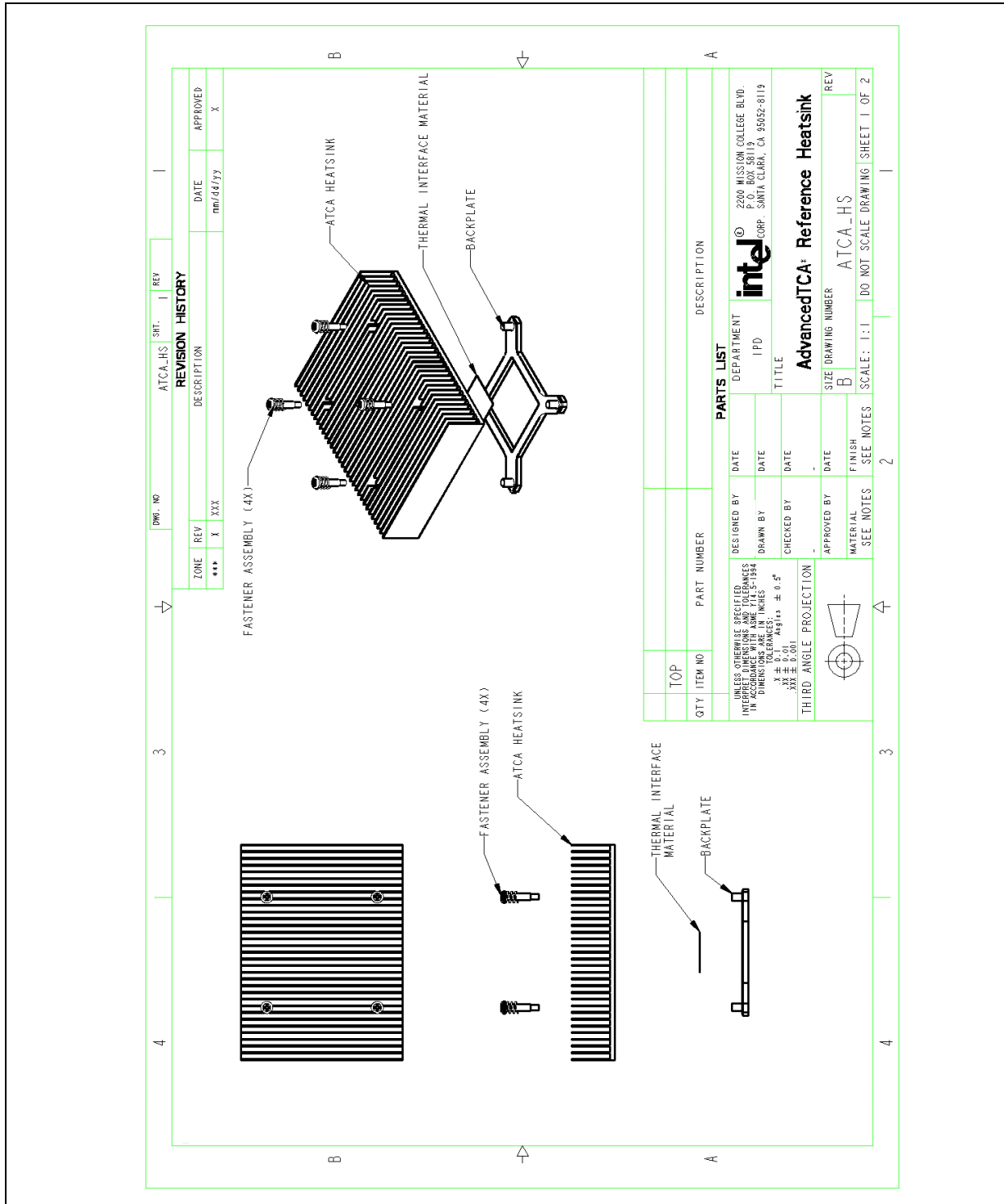

Figure 22. AdvancedTCA* Reference Heatsink

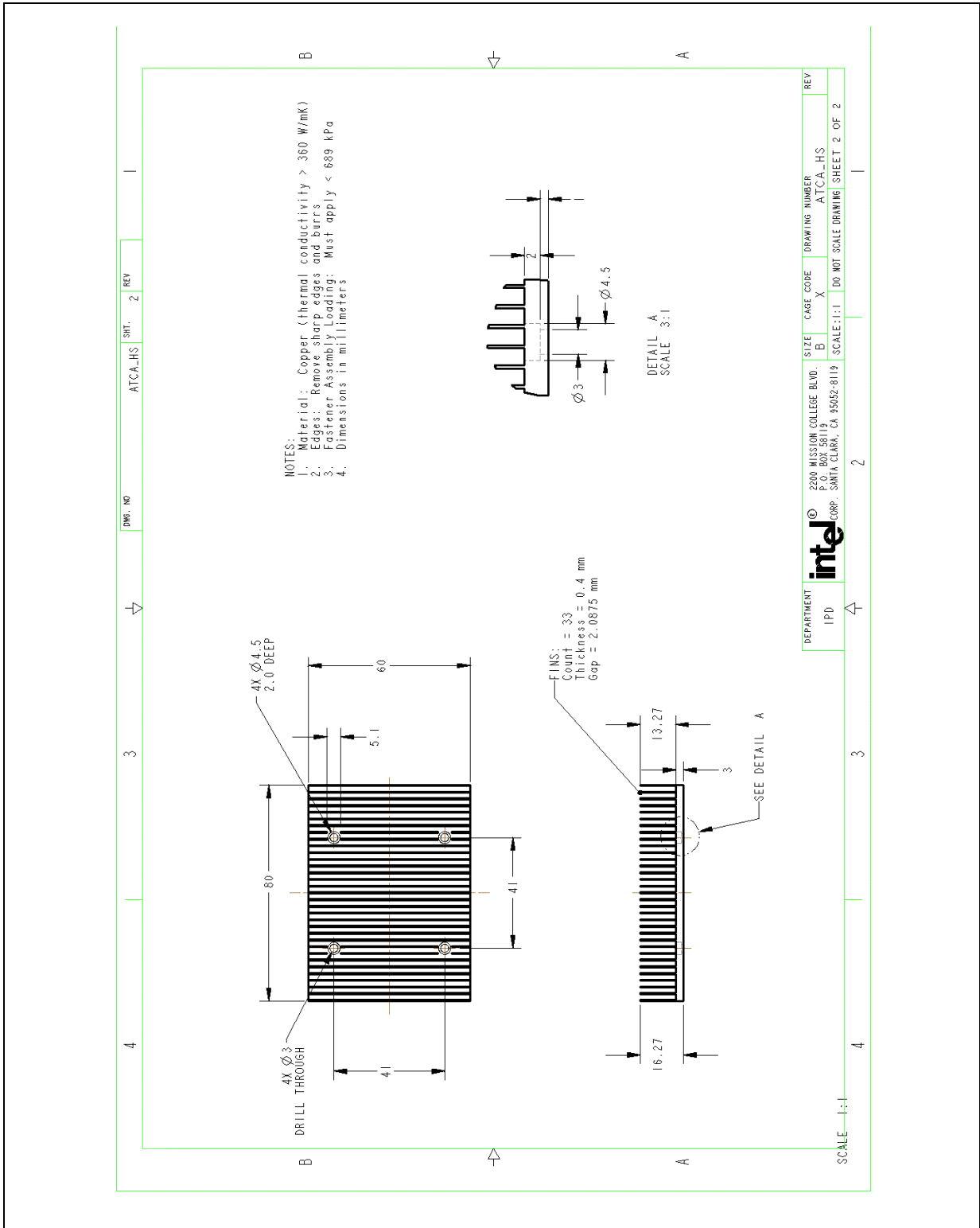

Figure 23. CompactPCI* Reference Heatsink PCB Keep Out Zone Requirements (Sheet 1 of 2)

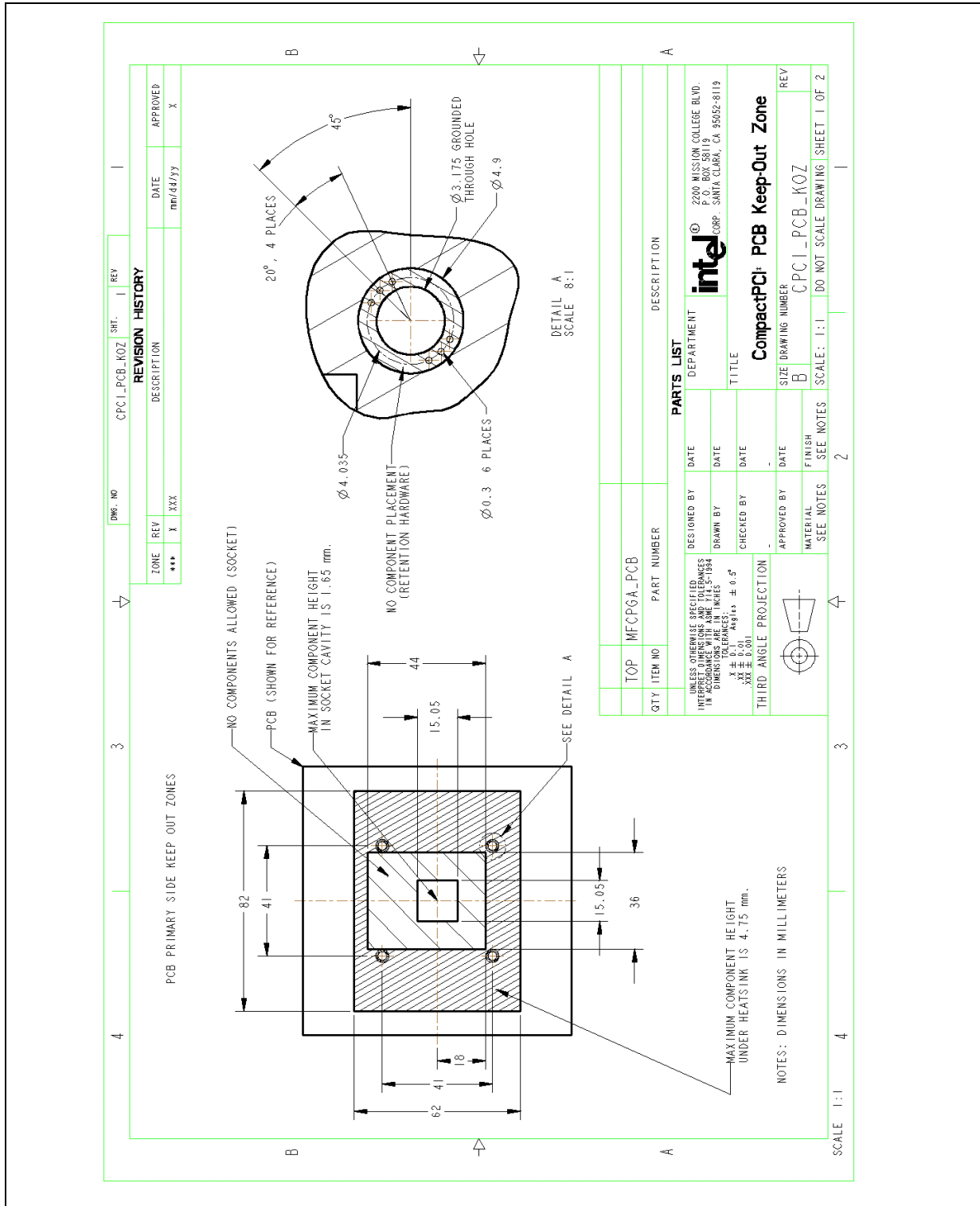

Figure 24. CompactPCI* Reference Heatsink PCB Keep Out Zone Requirements (Sheet 2 of 2)

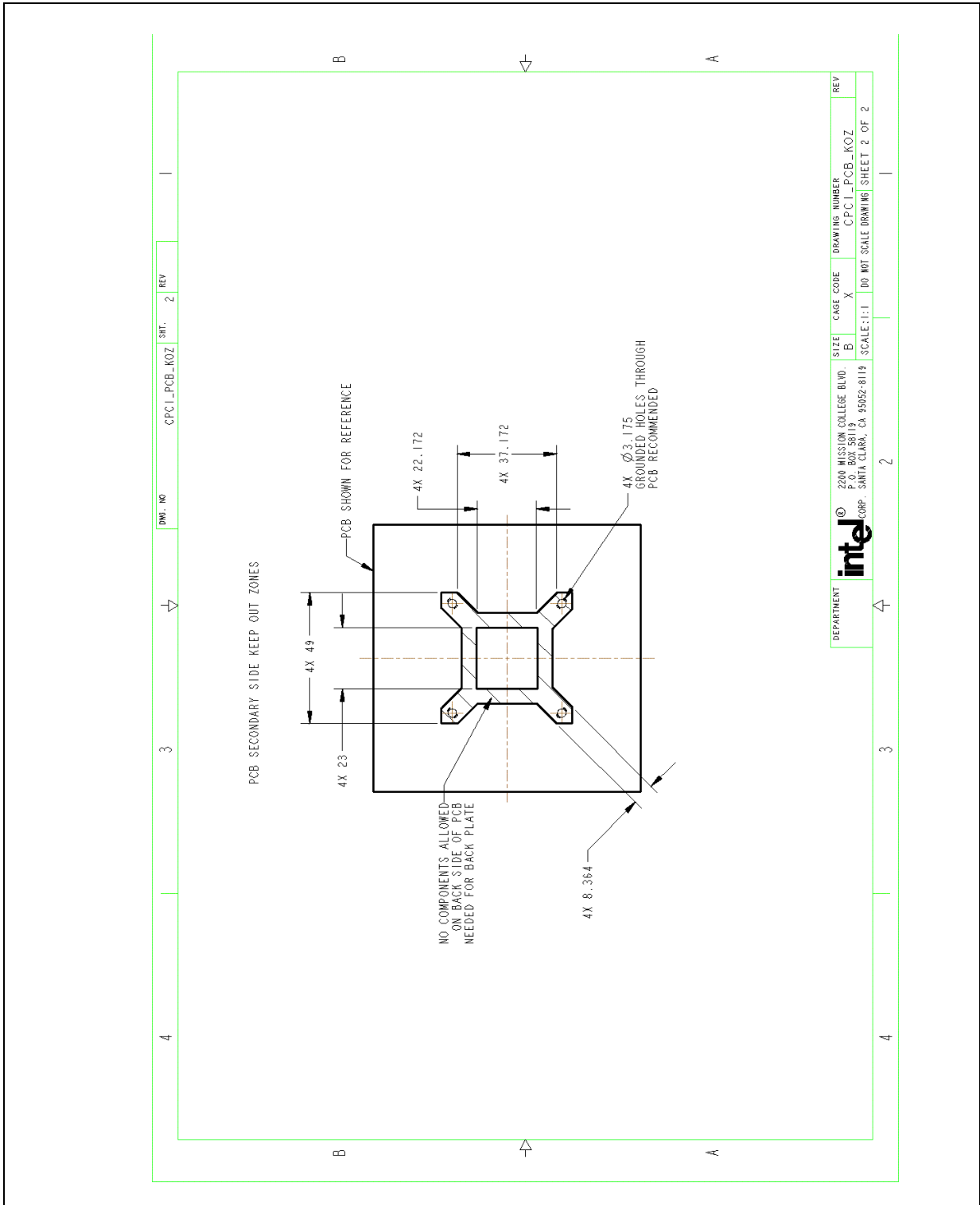

Figure 25. CompactPCI* Reference Heatsink Assembly

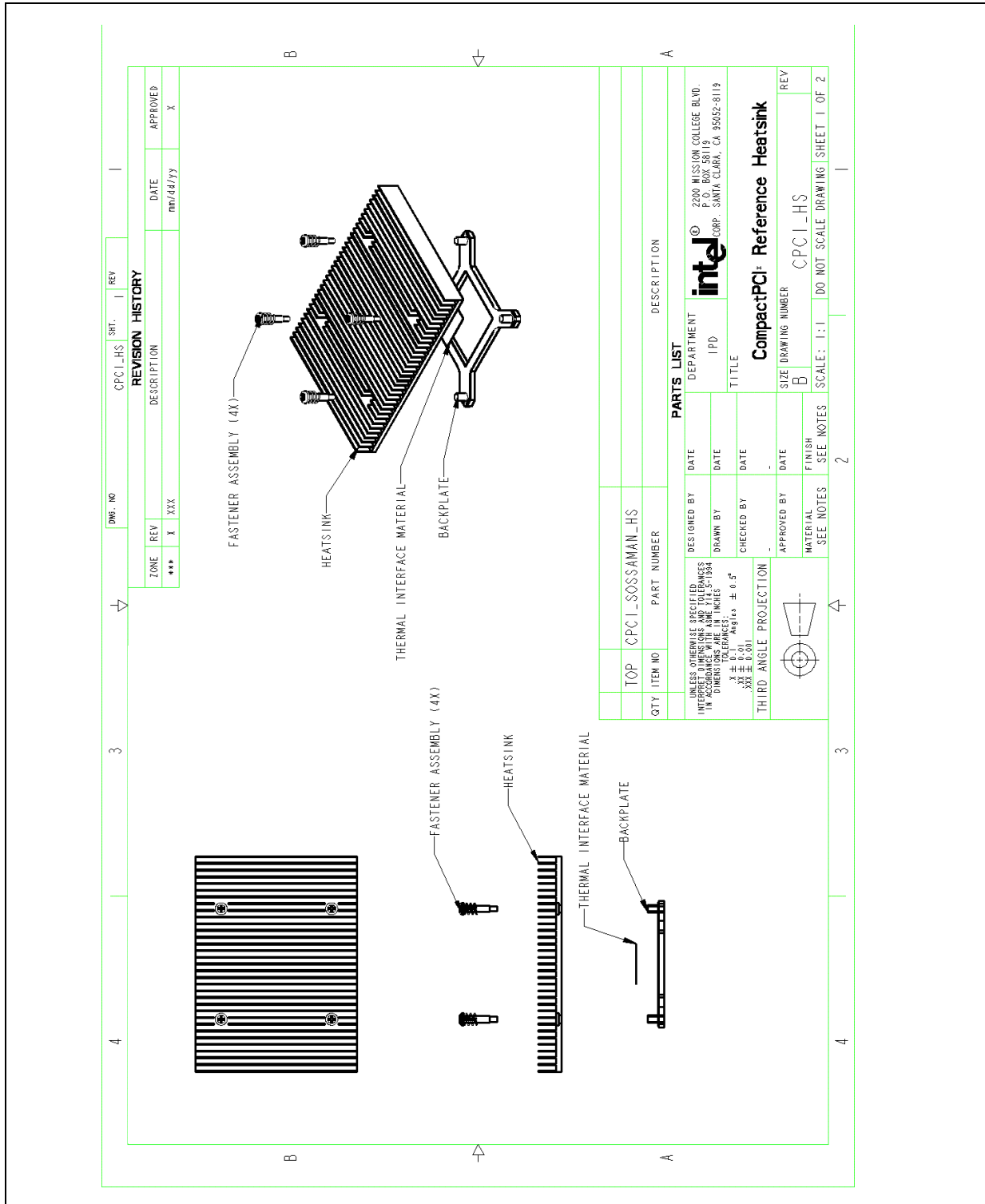

Figure 26. CompactPCI* Reference Heatsink

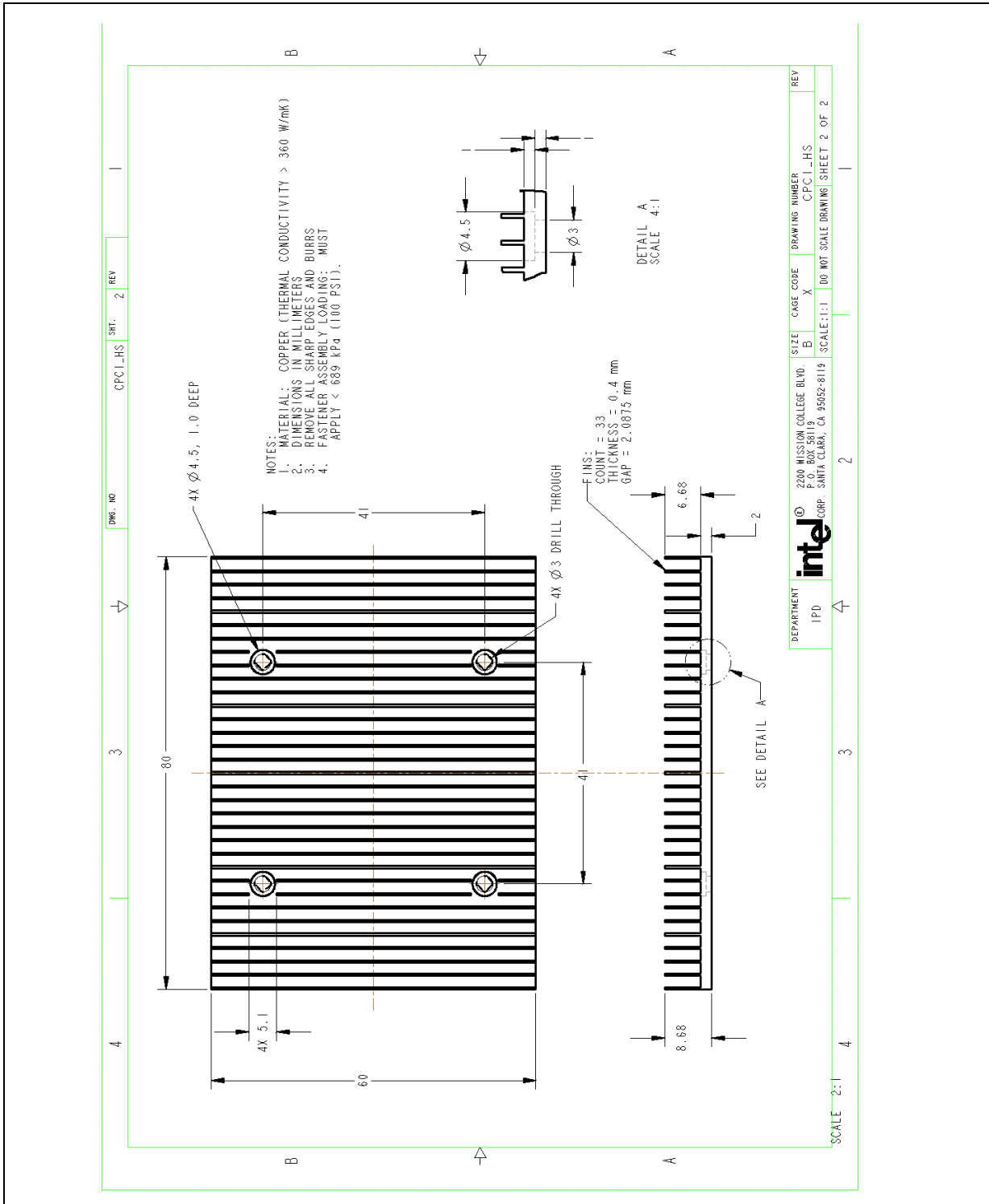

Figure 27. 1U Reference Heatsink PCB Keep Out Requirements (Sheet 1 of 2)

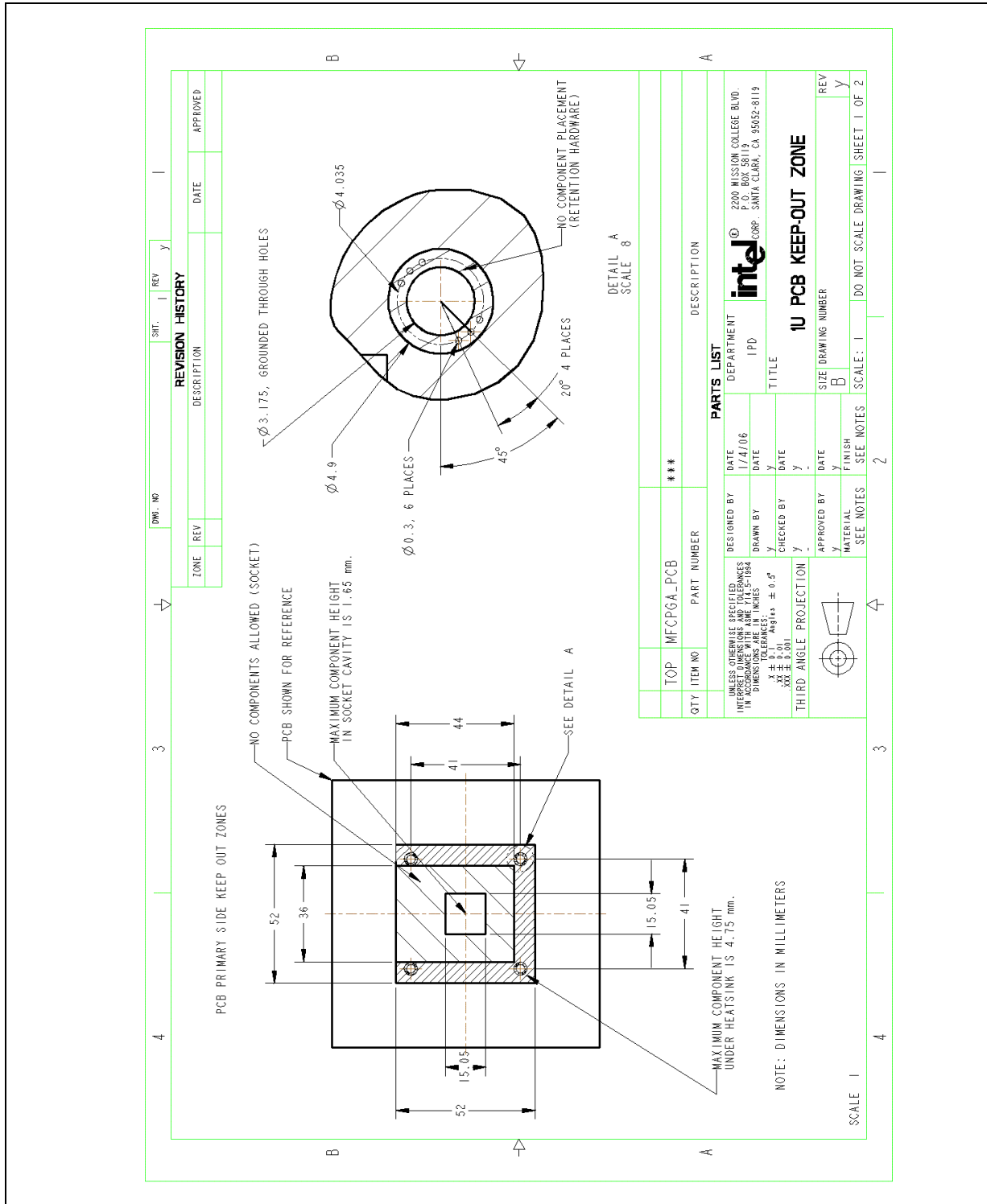

Figure 28. 1U Reference Heatsink PCB Keep Out Requirements (Sheet 2 of 2)

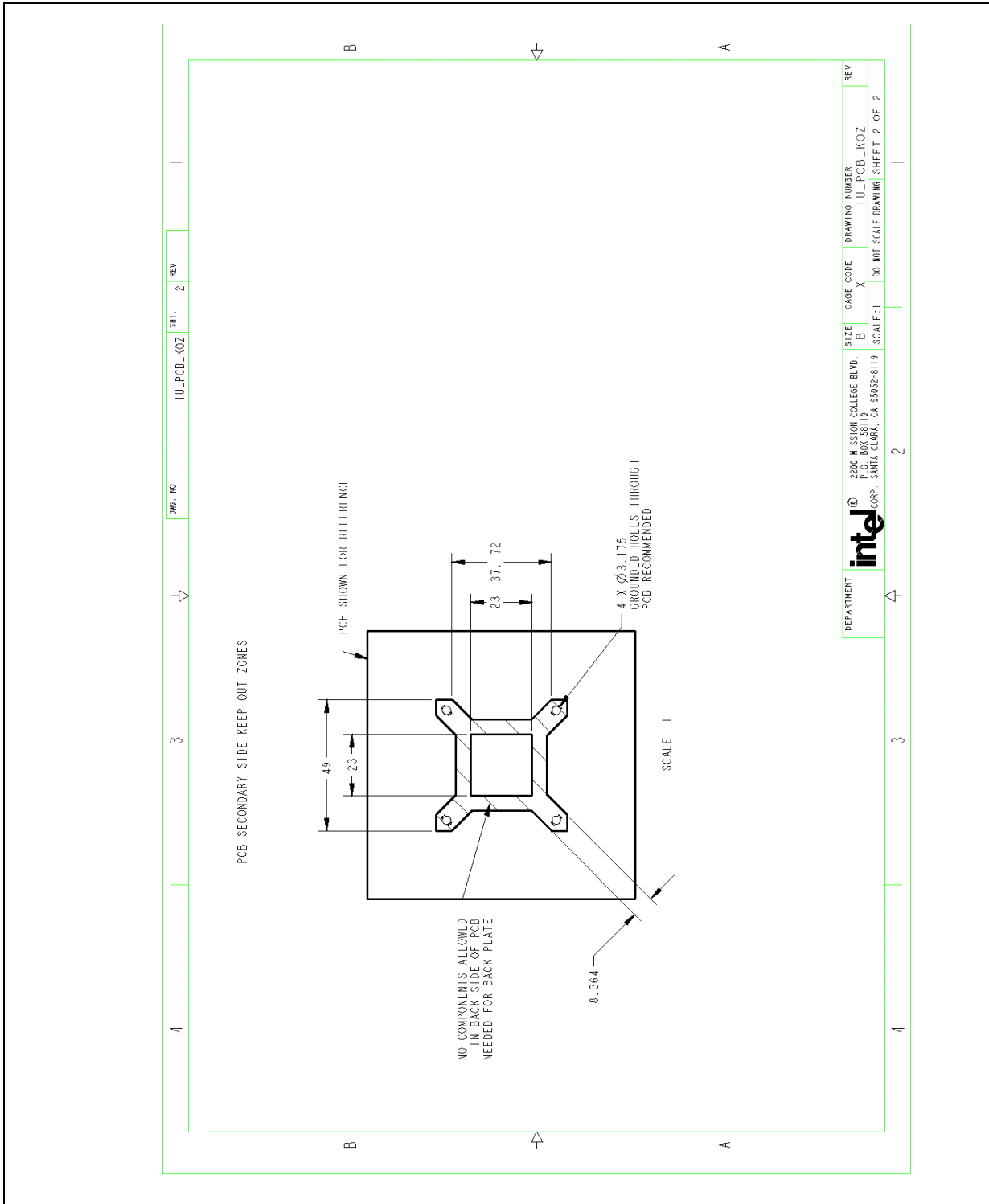

Figure 29. 1U Reference Heatsink Assembly

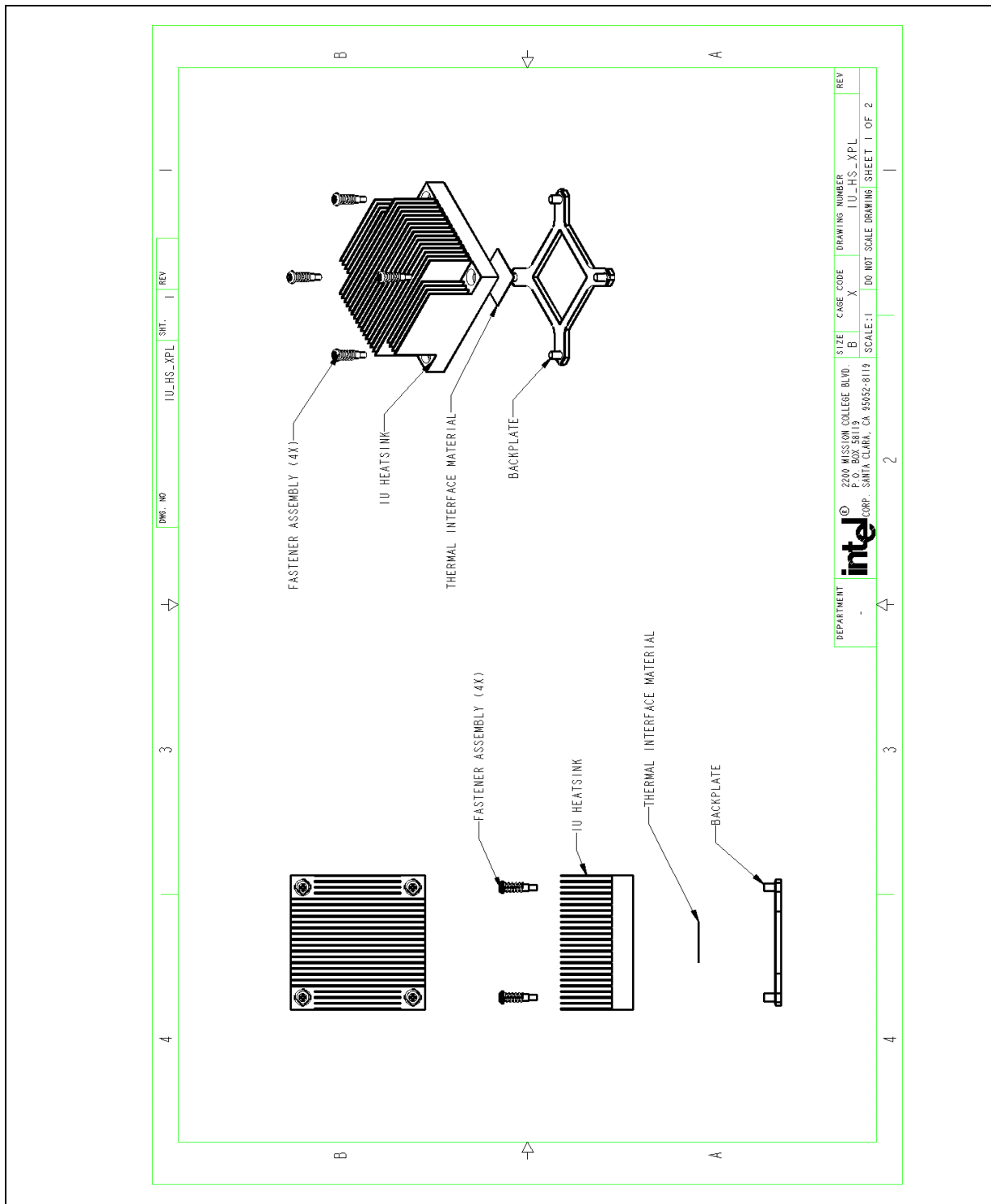

Figure 30. 1U Reference Heatsink

